

Structure of microfiche

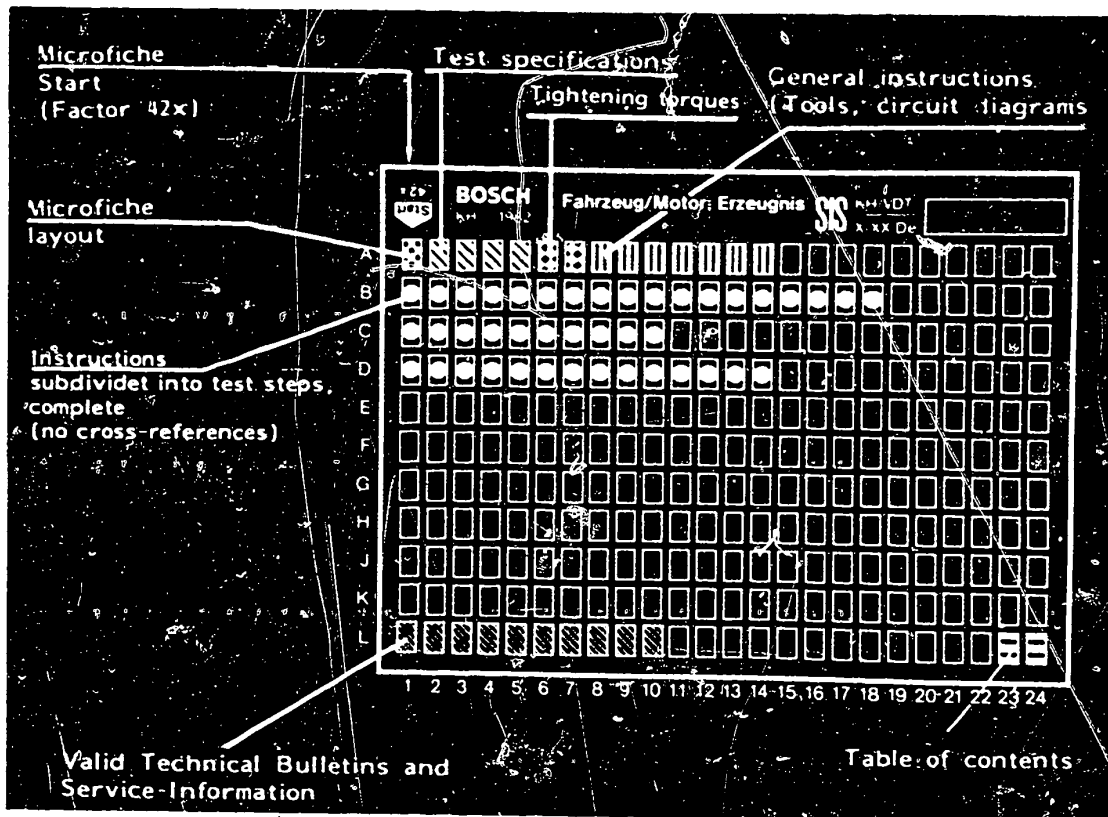

1. Read from left to right

2. Title of microfiche (appears on each coordinate)

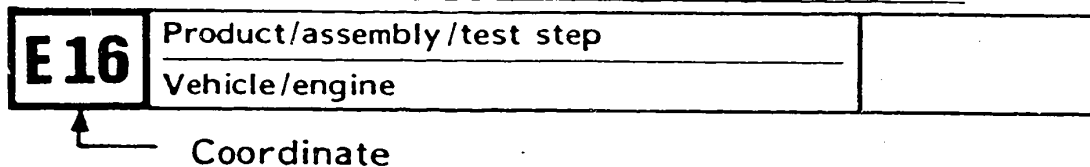

3. Limits of section

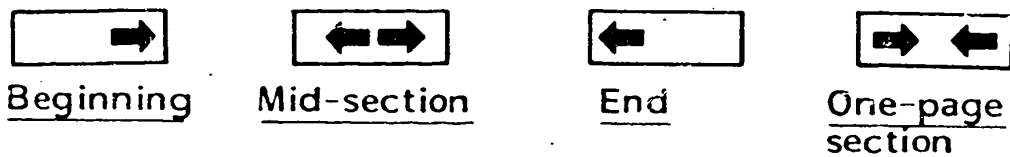

4. References to relevant test steps in test specifications; coordinate e.g. C6

C6



1. Test specifications - electrical

Suppression capacitor: 1.8 ... 2.5 μF

Resistance values:

Stator resistance 0.21 ... 0.24 Ω

Rotor resistance 9.0 ... 9.9 Ω

Power test with regulator

Set the regulated voltage on the test bench to 26V.

Alternator 0 120 4 ... N1 (RL) 28V55A25

Alternator speed ¹⁾ min ⁻¹	Load current A
1450	10
2500	36
6000	55

Regulated voltage 27.5 ... 28.4 V
at load current $\leq 10\text{A}$
and test speed = 6000 min⁻¹

1) Warm alternator (60°C) in case of transistor regulator

B4

B8

B14

D5

A2

Test specifications - electrical
Alternators 0 120 4 ..., 28V



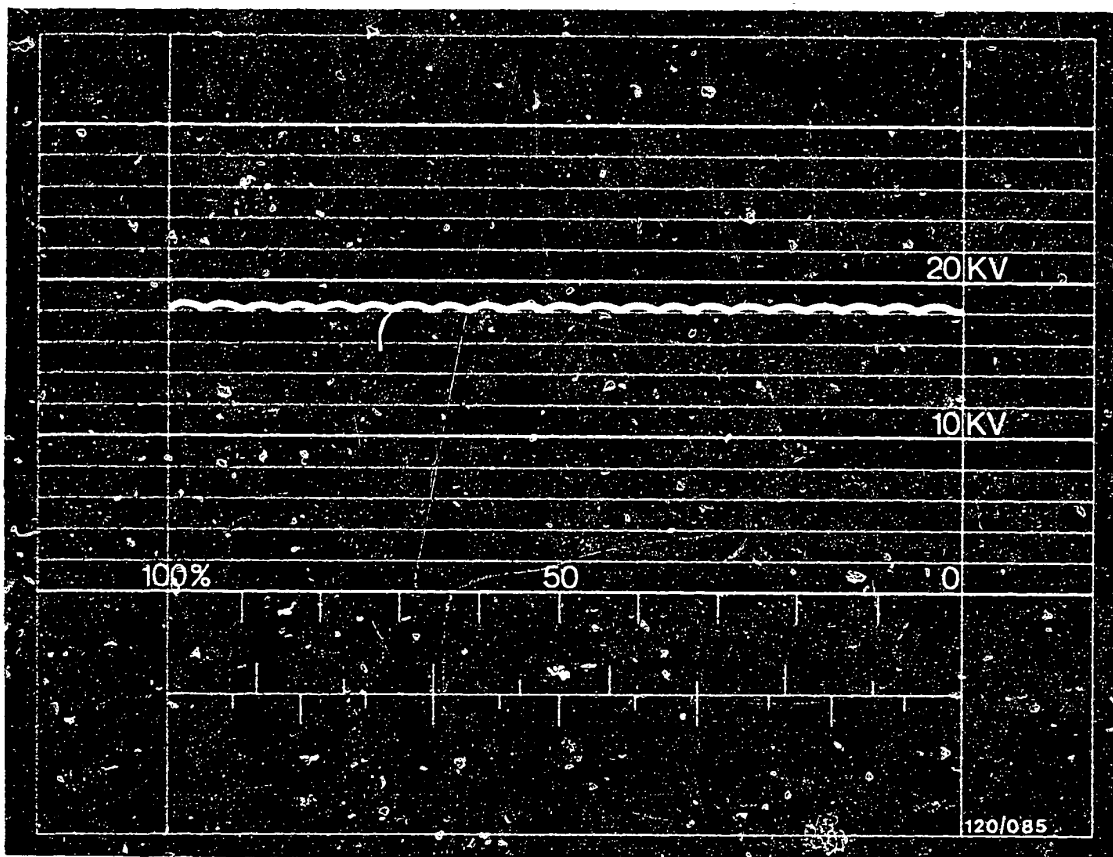

Oscilloscope display OK

If the alternator is OK, the above oscilloscope pattern will be displayed. The DC output has a slight ripple. The pattern can exhibit small peaks when the voltage regulator comes into operation. The regulator can be stopped by means of switching in loads (e.g. load resistor).

Adjust the pattern height so that the ripple is contained between two adjacent kV lines.

In order to be able to compare such patterns, the pattern concerned is to be adjusted with the vertical control of the oscilloscope so that it fits approximately between the 10 kV and 20 kV lines.

Note: more than one defect can be present at one time.

A3

Electrical test data

Alternators 0 120 4 .., 28 V



2. Mechanical test data

Deviations from true running

Outer diameter of the rotor: 0.05 mm

Outer diameter of the collector ring: 0.03 mm

Minimum diameter of the collector rings: 26,8 mm

Carbon-brush projection, new: 14,0 mm

Minimum brush projection: 5,0 mm

B 16

B 16

B 3

A4

Mechanical test data

Alternators 0 120 4 .., 28 V



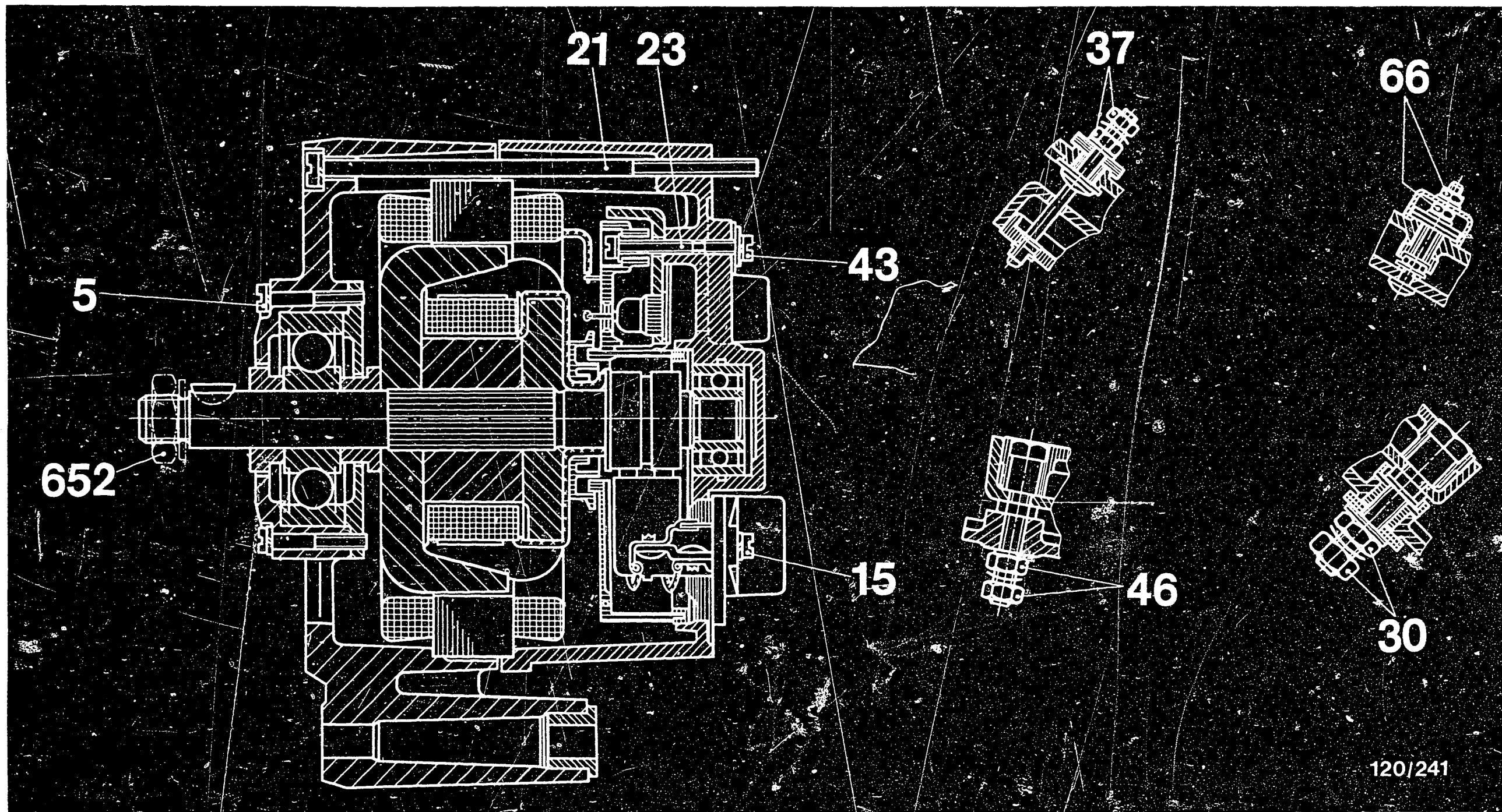

120/241

2.1 Tightening torques for alternator 0 120 469 ..

Item 5 = 2.2 ... 2.9 Nm	Item 37 = 2.7 ... 3.8 Nm
Item 15 = 1.6 ... 2.3 Nm	Item 43 = 1.4 ... 2.0 Nm
Item 21 = 4.1 ... 5.5 Nm	Item 46 = 4.8 ... 6.8 Nm
Item 23 = 1.4 ... 2.0 Nm	Item 66 = 1.4 ... 2.0 Nm
Item 30 = 7.5 ... 8.0 Nm	Item 652 = 35 ... 45 Nm

A5 Mechanical test data
 Alternators 0 120 4 .., 28 V

↔

A6 Mechanical test data
 Alternators 0 120 4 .., 28 V

←

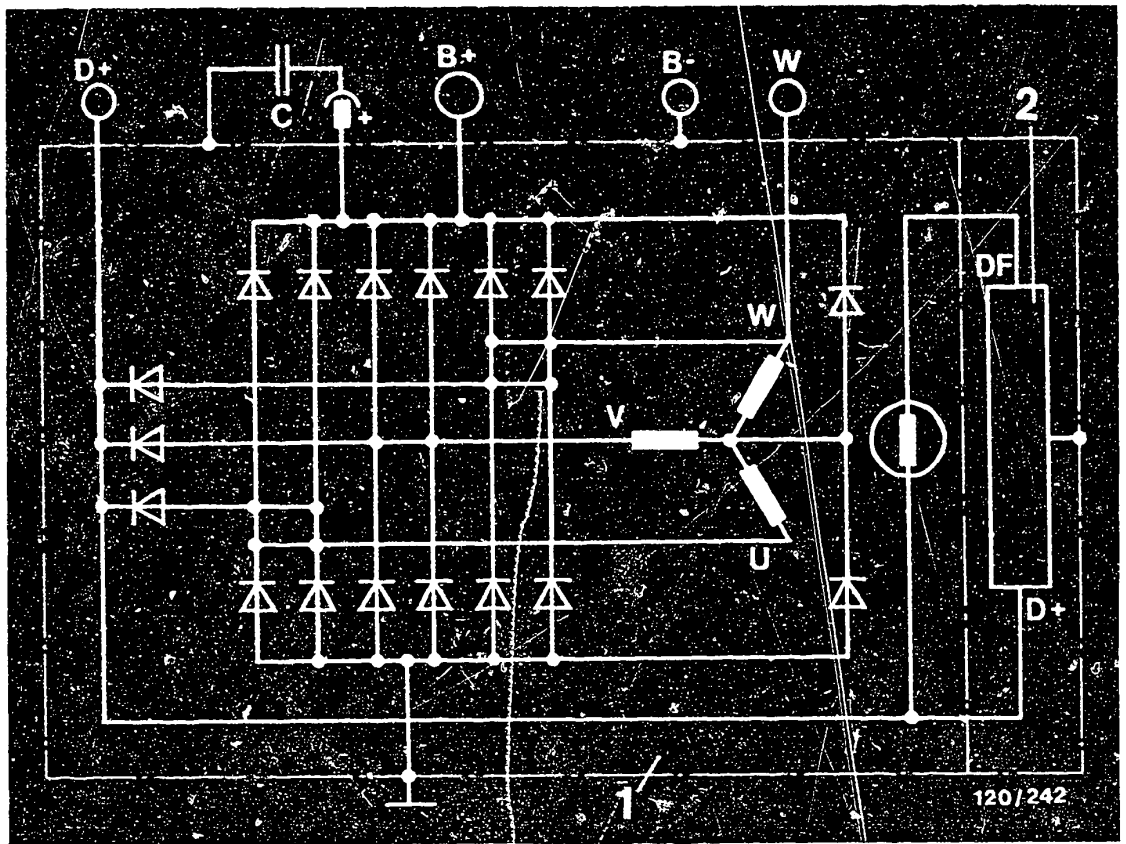

1 = Alternator
 2 = Regulator

3. Circuit diagram of alternator

Alternator 0 120 469 ..

N1 - 28 V 55A 25

A7

Circuit diagram

Alternators 0 120 4.., 28 V



4. General Information

Explanation of type code on alternator

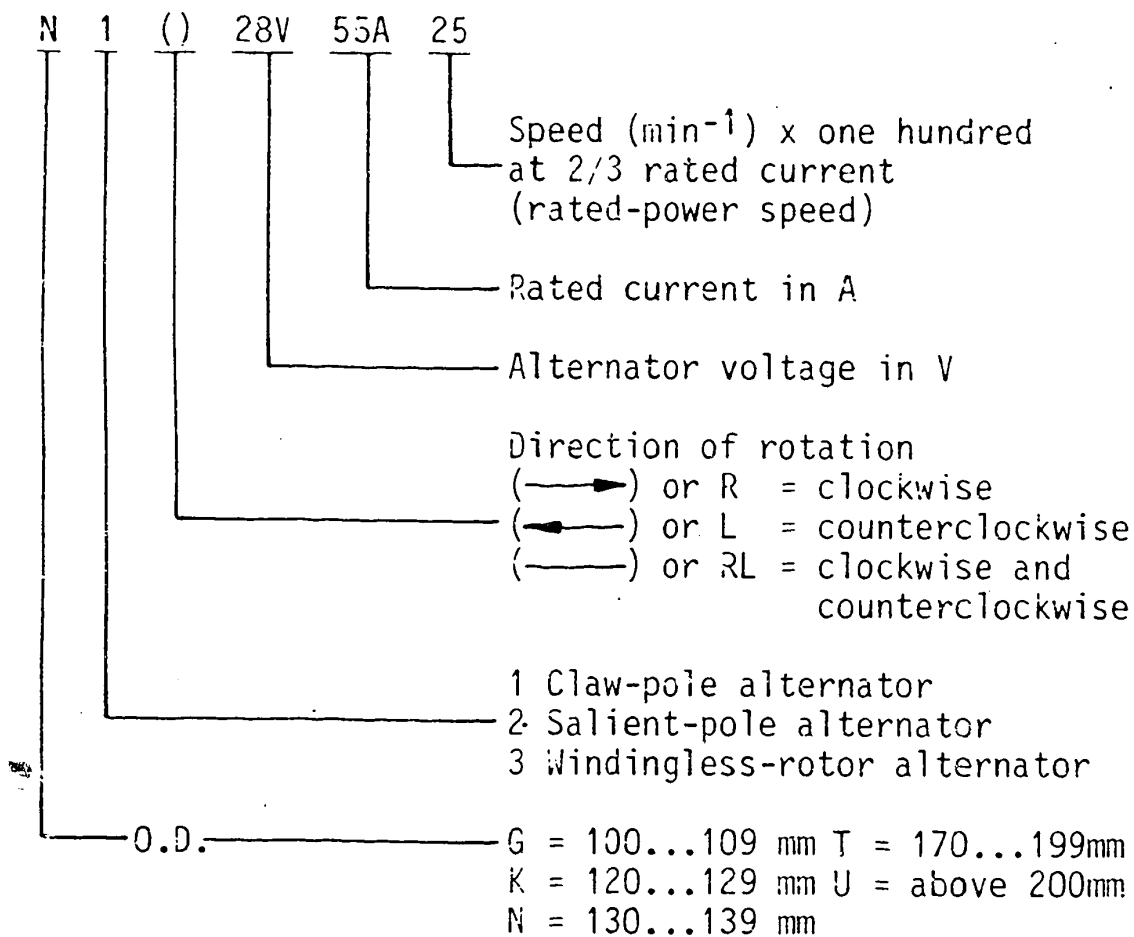

A8

General information

Alternators 0 120 4 .., 28V



Cleaning the parts

CAUTION! FIRE HAZARD!

Alternators are being increasingly fitted with long-storage capacitors (e.g. for the interference suppression of receivers and transmitters).

When washing parts of the alternator it is possible for the capacitor to discharge when immersed in cleaning fluids, there then being the danger that inflammable liquids will ignite. For this reason, parts with capacitors must only be washed in tri- or perchloroethylene.

Remark:

Alternator 0 120 469 521 was used in preparing the present repair instructions.

Please refer to the respective spare-part microcards for the different alternator types.

A9

General Instructions

Alternators 0 120 4 .., 28 V



5. Test equipment, tools and adhesives

5.1 Test equipment

Alternator test bench	EFLJ 91	0 683 300 100
	or EFLJ 25..	0 680 110 ..
	or EFLJ 70 A	0 680 104 ..
or combination test bench (only for loading up to max. 43 A)	EFAW 275..	0 681 107 ..
Mounting plate for mounting swivel-arm- mounted alternators on alternator test bench	EFLJ 66/3 EFLJ 25, 70	
Parts set for mounting swivel-arm- mounted alternators on combination test bench	EFAW 275 ..	1 687 000 042
For additional test:		
Ignition oscilloscope	(all models)	
or		
Bosch Motortester	(all models)	



Test equipment (continued)

Test panel	EFAW 81 or KDAW 9984	0 681 169 013
Transformer panel	EFAW 82 or KDAW 9985	0 681 169 014
Insulation tester or test prods	EFAW 84 KDAW 9983	(Included with EFAW 81 or KDAW 9984)
Dial indicator	EFAW 7	1 687 233 011
Magnetic instrument stand	T-M1 (EW/MS 1 B 1	4 851 601 124 0 601 980 001)
Alternator tester	EFAW 192 or WPG 012.00	0 681 101 403 0 684 201 200
3 Feeler gauges 0.15 ... 0.6 mm	KDZV 7399	
Electric tester	ETE 014.00	0 684 101 400

A11

Test equipment and tools

Alternators 0 120 4.., 28 V



5.2 Tools

Press-in mandrel	KDLI 6002
Press-on mandrel for collector rings	KDLI 6004/1 KDLI 6004/0/1
Holding device for pulley	KDLI 6006
Clamping pin for arbor press	KDLI 6010
Clamping support Arbor press	KDAW 9999 (commercially available)
Two Vee-blocks	(commercially available)
Soldering iron 180W	(commercially available)
Press-out ring for rotor e.g. old stator frame of starting motor	I.D. 105 mm O.D. 115 mm

5.3 Adhesives

Adhesive dispersion KK57v1	Part No: 5 703 151 000
----------------------------	---------------------------



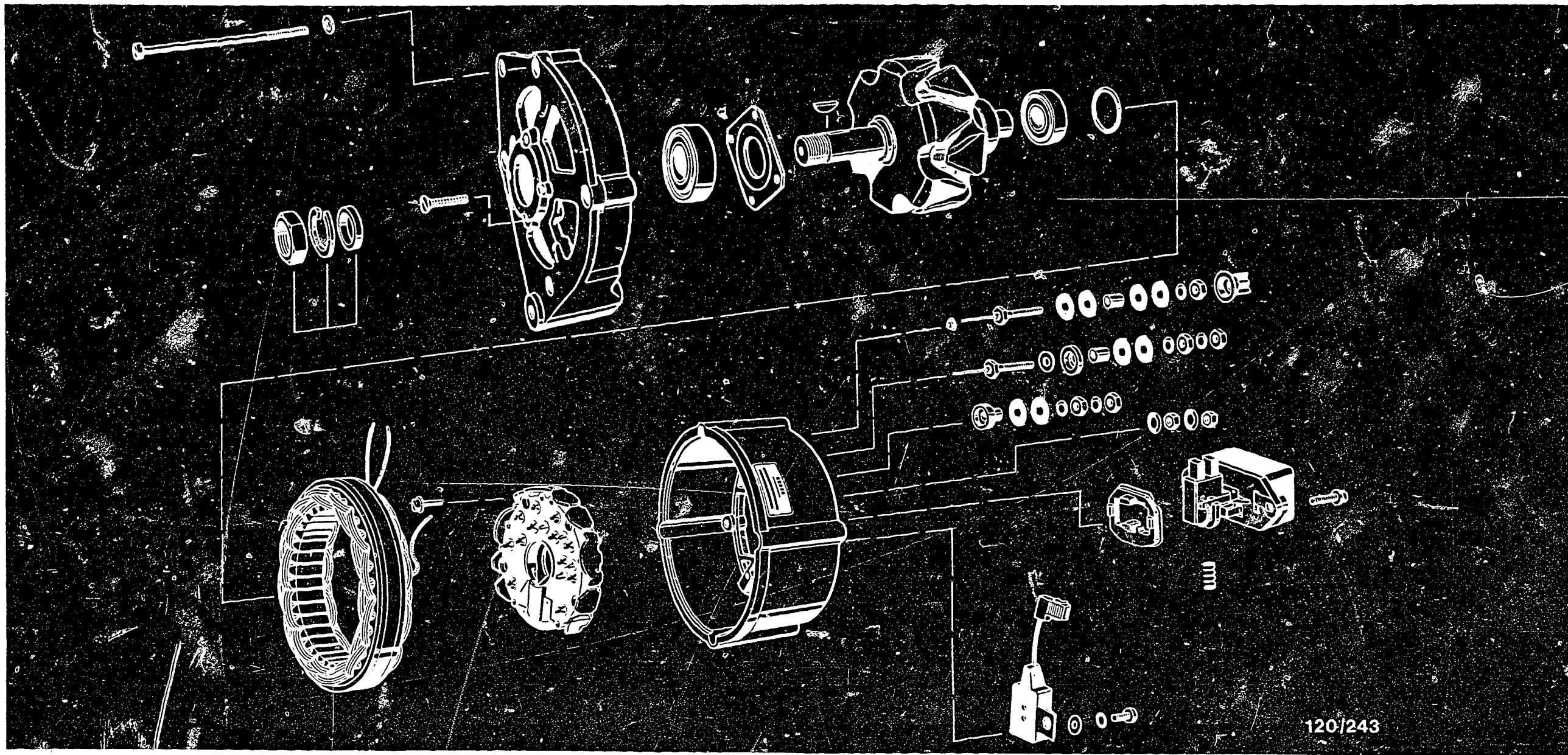

120/243

6. Exploded view of alternator 0 120 469 521

(N1 - (RL) 28V 55A 25)

A13

Exploded view

Alternators 0 120 4..., 28 V



A14

Exploded view

Alternators 0 120 4..., 28 V



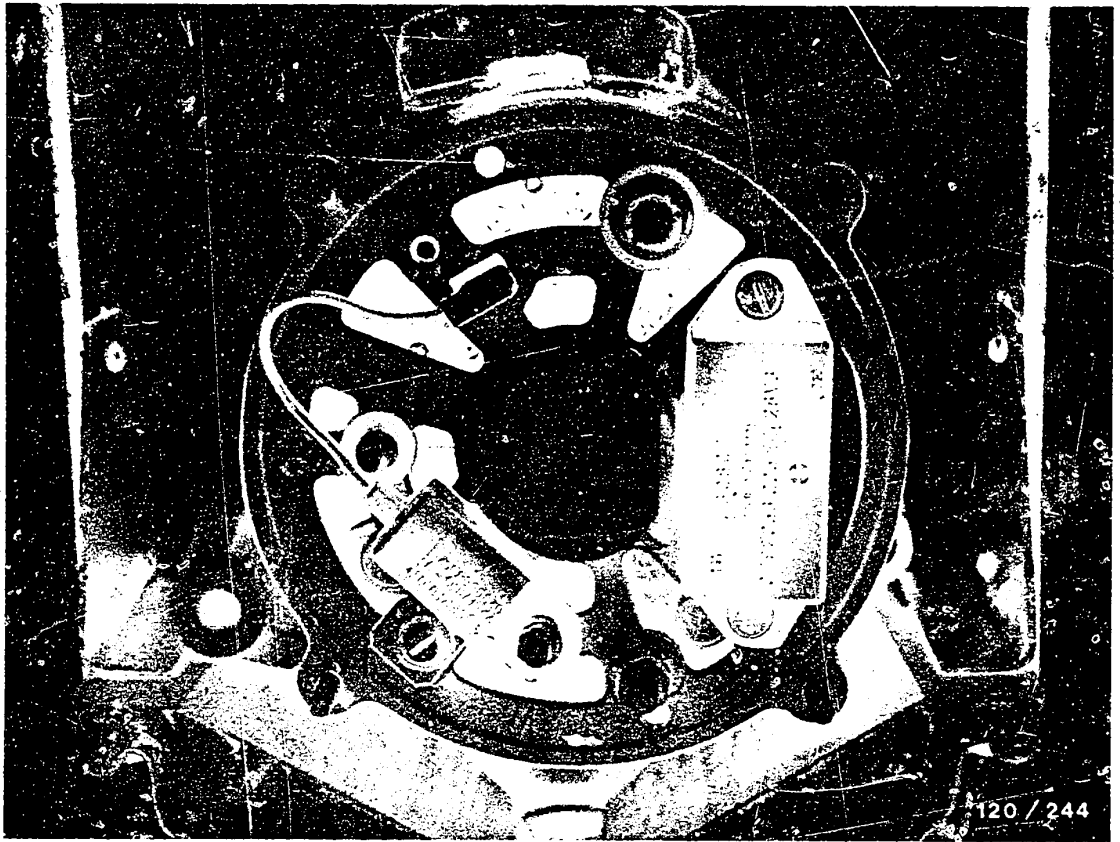

7. Dismantling the alternator and testing the parts

Clamp the alternator in clamping support KDAW 9999.

B1

Dismantling the alternator

Alternators 0 120 4.., 28 V



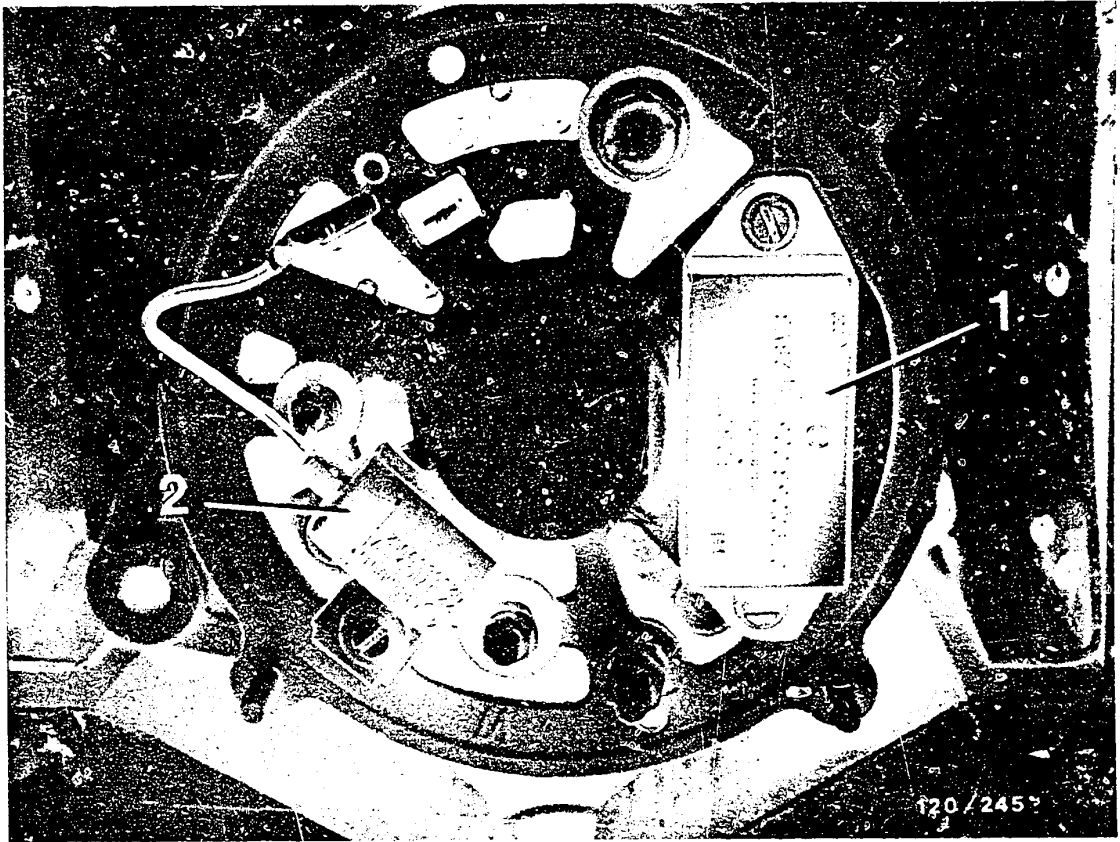

- 1 = Electronic regulator with carbon-brush holder
2 = Capacitor

Caution!

Before further dismantling the alternator, first of all remove the electronic regulator.

To do this, unscrew the ② fastening screws on the regulator.

If this sequence of operations is not followed, the carbon brushes will break when the alternator is taken apart.

B2

Dismantling the alternator

Alternators 0 120 4 .., 28 V



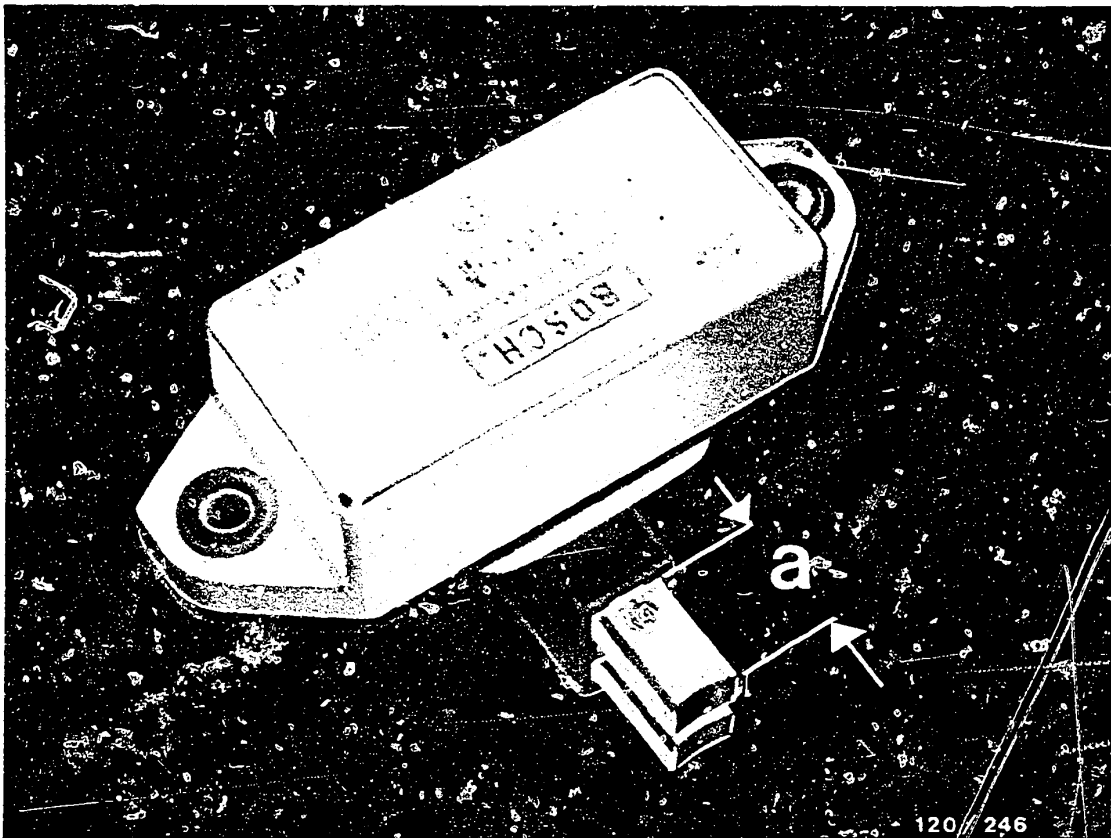

7.1 Testing the regulator for external damage and replacing the carbon brushes

If carbon brushes are broken off, or if projection dimension "a" is less than 7 mm, replace the carbon brushes.

Observe dimension "a" when soldering in the new carbon brushes.

Brush projection dimension new	14.0 mm
Minimum projection of brushes	5.0 mm

Note:

Solder (colophonium tin only) must not flow into copper strand.

After installing, check carbon brushes for freedom of movement.

B3

Dismantling the alternator

Alternators 0 120 4 .., 28V

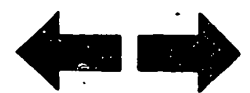

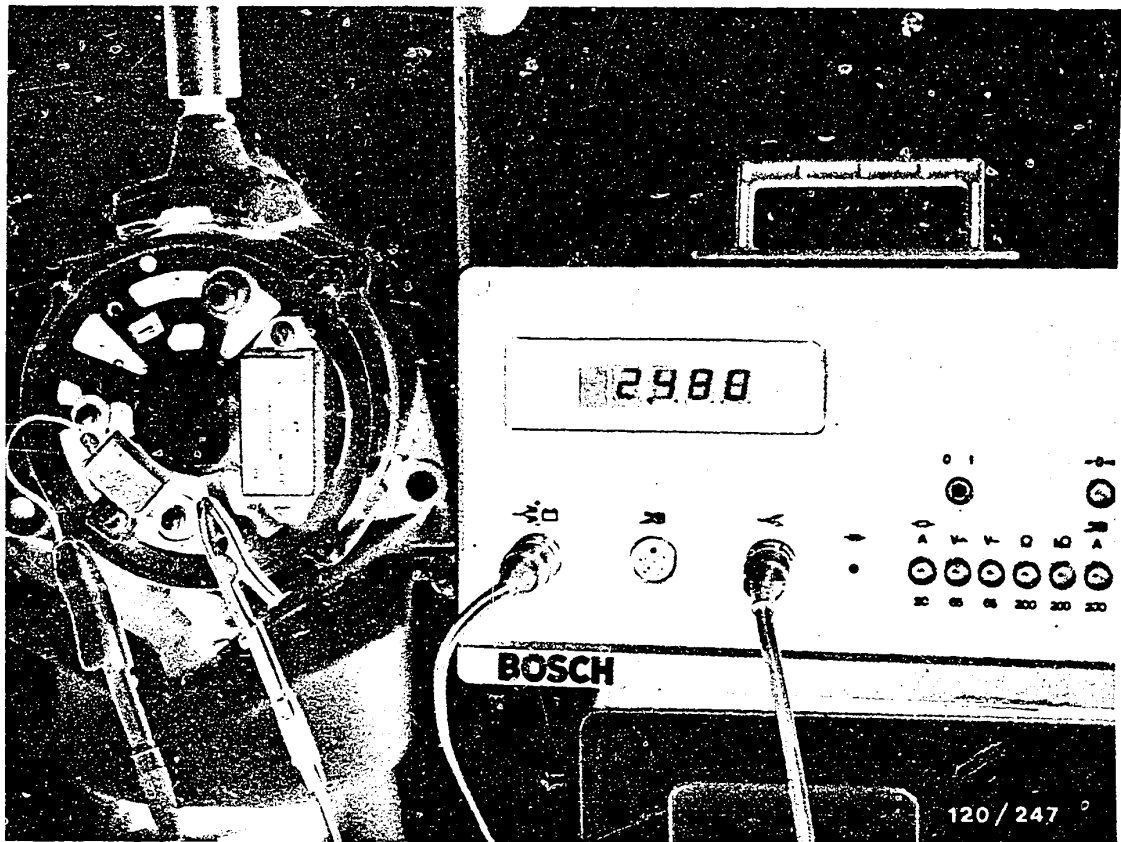

7.2 Testing the suppression capacitor

Remove lead of suppression capacitor from terminal B+. Connect electric tester between lead of suppression capacitor and terminal B- of alternator (picture). Set value: 1.8 ... 2.6 μF .

If this value is not reached, replace the defective suppression capacitor. After testing, discharge the suppression capacitor by short-circuiting so that there is no possibility of the cleaning liquid igniting when the parts are cleaned.

B4

Dismantling the alternator

Alternators 0 120 4 .., 28 V



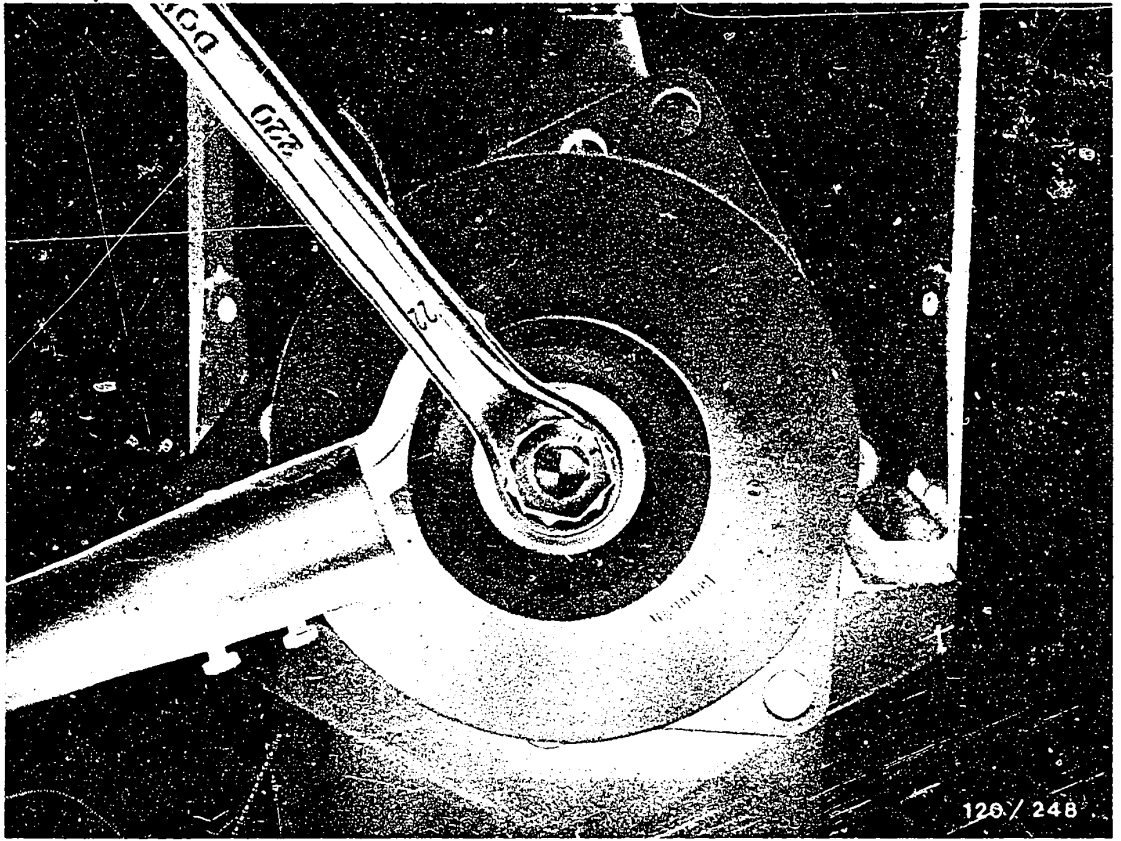

Using holding tool KDLI 6006 and 22 mm ring wrench,
loosen fastening nut and remove pulley with fan.

B5

Dismantling the alternator

Alternators 0 120 4..., 28 V



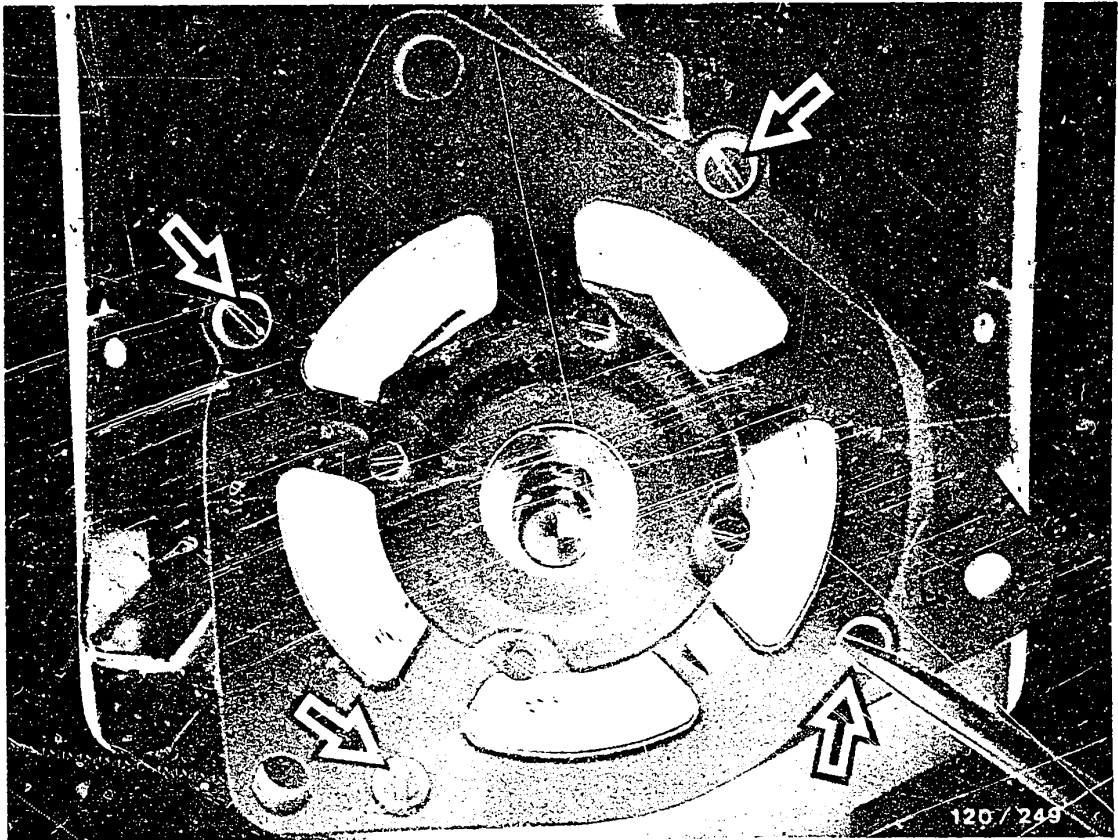

Caution

Before the alternator is further dismantled, mark the drive end shield, collector-ring end shield and stator so that these parts are brought into the same position again when assembling.

Loosen four fillister-head screws (arrows) and remove. Withdraw drive end shield with rotor from collector-ring end shield.

B6

Dismantling the alternator

Alternators 0 120 4 .., 28 V



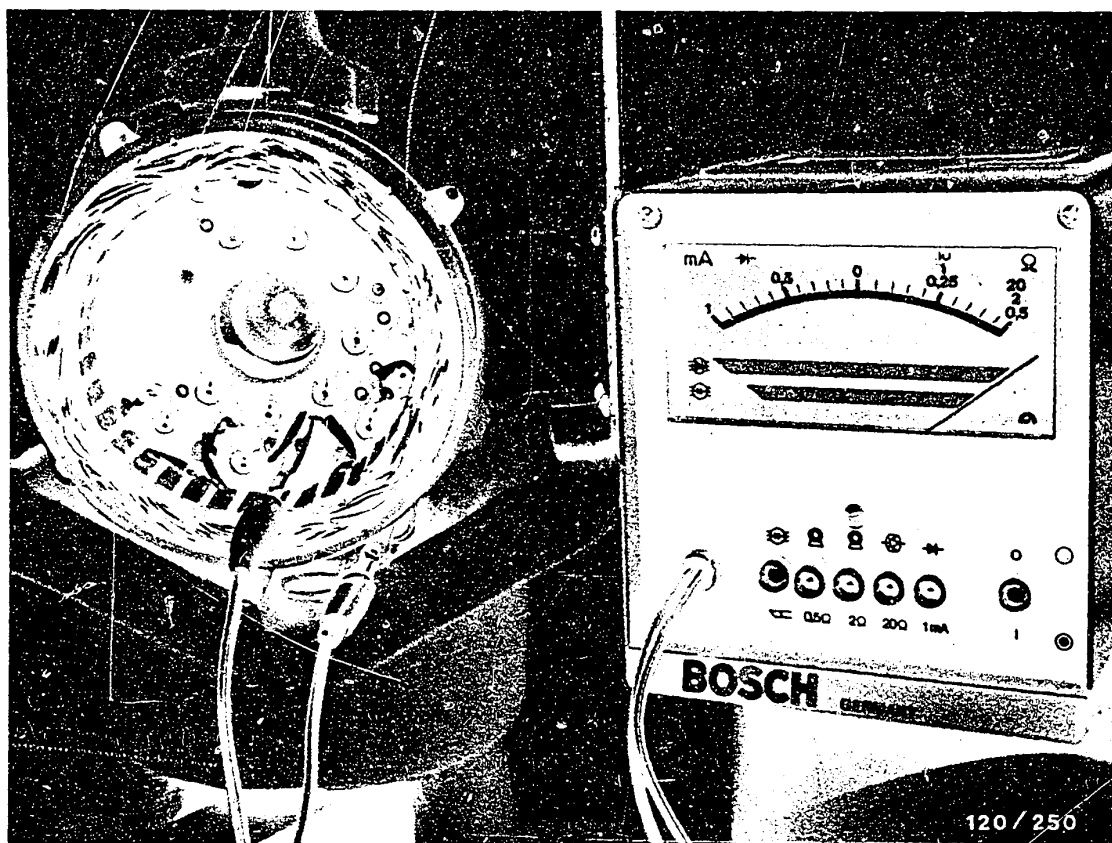

7.3 Testing the rectifier

Test the proper operation of the rectifier when connected up using EFAW 192 or WPG 012.00. Capacitor not connected. Note switch position on tester.

Test points:

Housing and winding ends

B+ and winding ends

D+ and winding ends

Rectifier is OK if the pointer of the tester is in the green area when testing.

If one or more diodes are defective, replace the complete rectifier.

B7

Dismantling the alternator

Alternators 0 120 4 .., 28 V



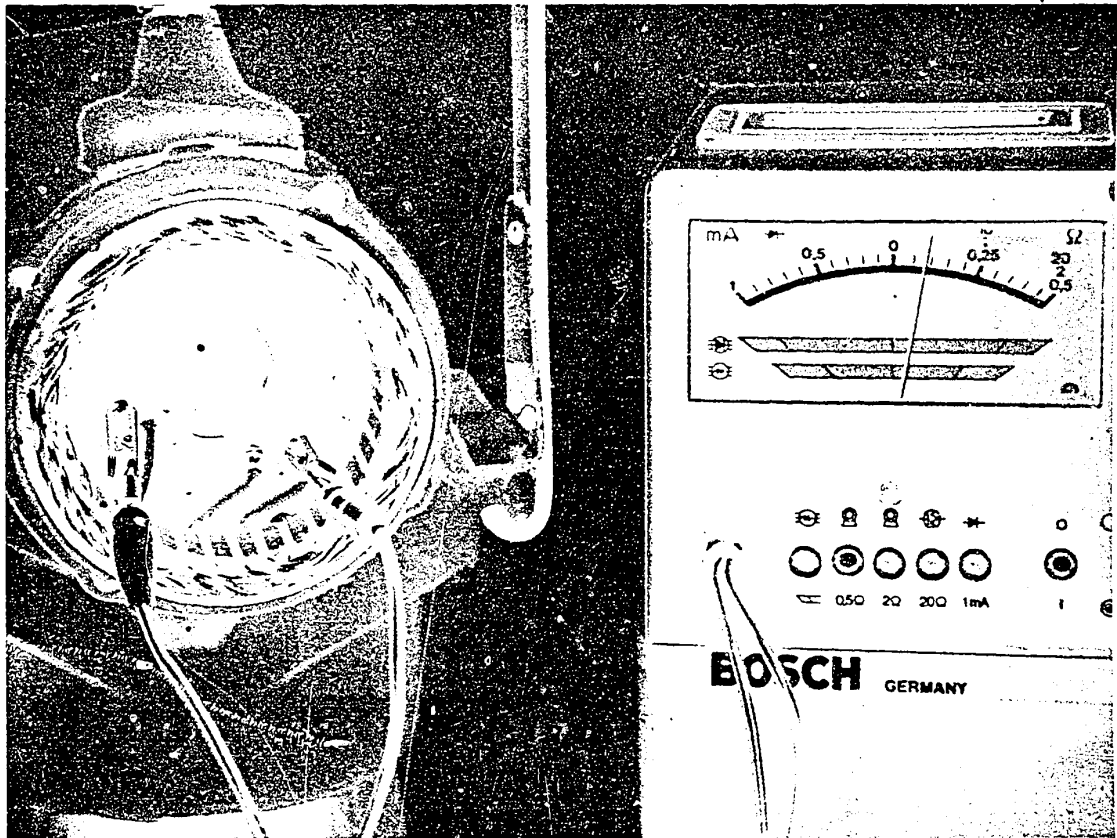

7.4 Testing the stator (resistance)

With the stator installed, test its resistance (picture).

Note switch position on tester.

Resistance 0,21 ... 0,24 Ω

Repeat test with stator removed (not shown).

Resistance 0,21 ... 0,24 Ω

B8

Dismantling the alternator

Alternators 0 120 4 ..., 28 V



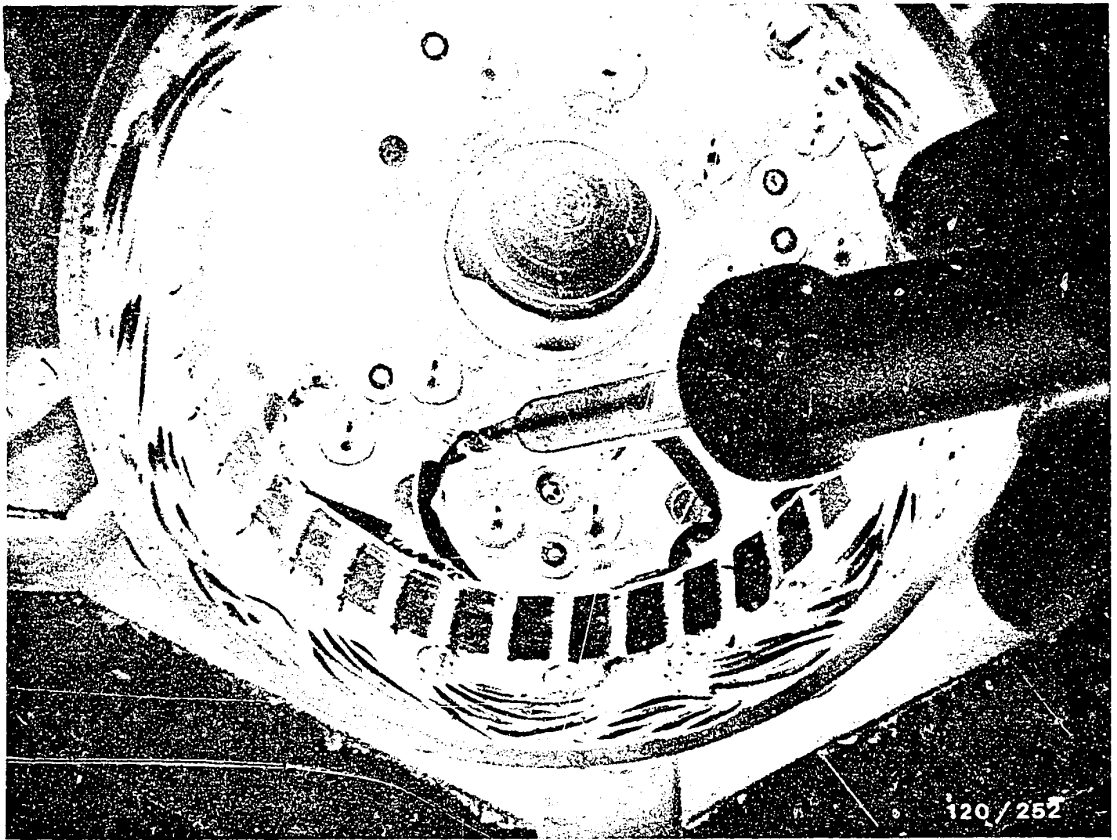

Removing the stator

Remove solder from the phase connections using soldering iron or soldering gun. Using a screwdriver, straighten the ends of the leads and pull the leads out of the fastening holes.

B9

Dismantling the alternator

Alternators 0 120 4 ..., 28 V



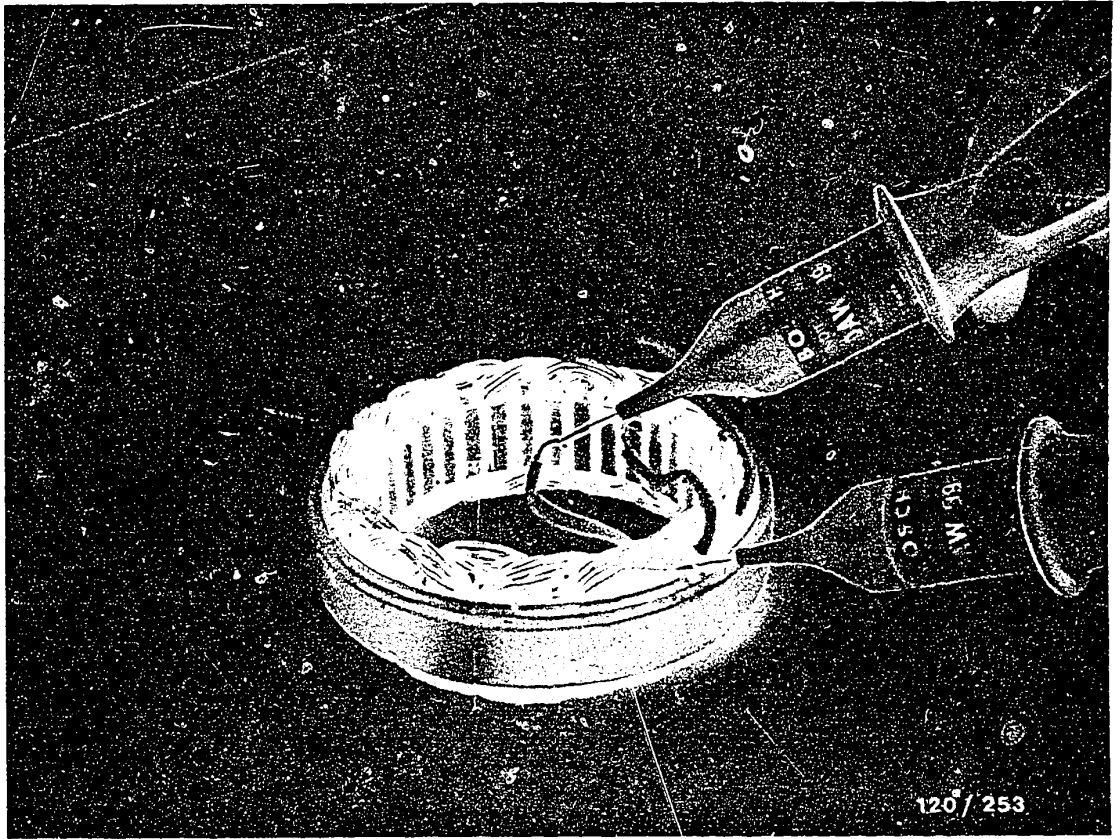

7.5 Testing the stator for short circuit to ground

Using test prods EFAW 84 or KDAW 9983, test the stator for short circuit to ground.

Test voltage 80V a.c.

B 10

Dismantling the alternator

Alternators 0 120 4..., 28V



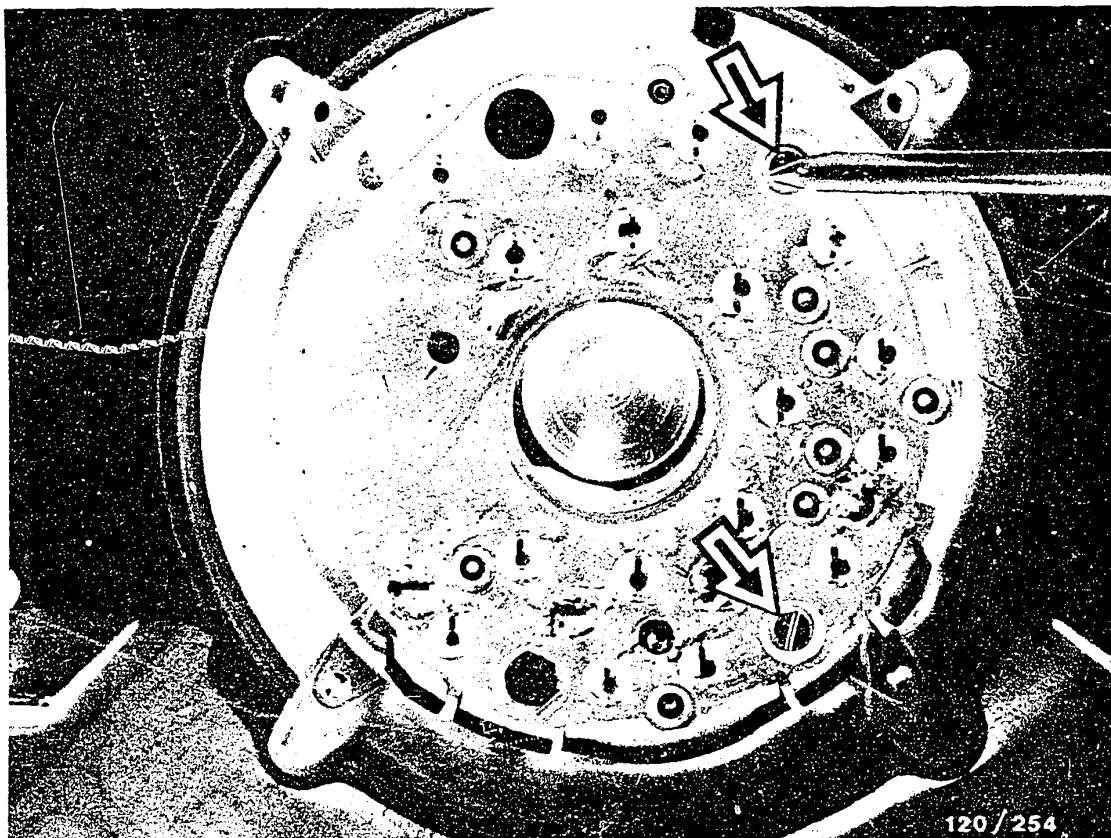

Removing the rectifier

Remove 2 or 3 washer-and-screw assemblies on inside of rectifier (picture).

Loosen terminal studs B+, B-, W and D+ on outside of collector-ring end shield. They are rigidly mounted on the rectifier.

Withdraw rectifier from collector-ring end shield.

B11

Dismantling the alternator

Alternators 0 120 4..., 28 V



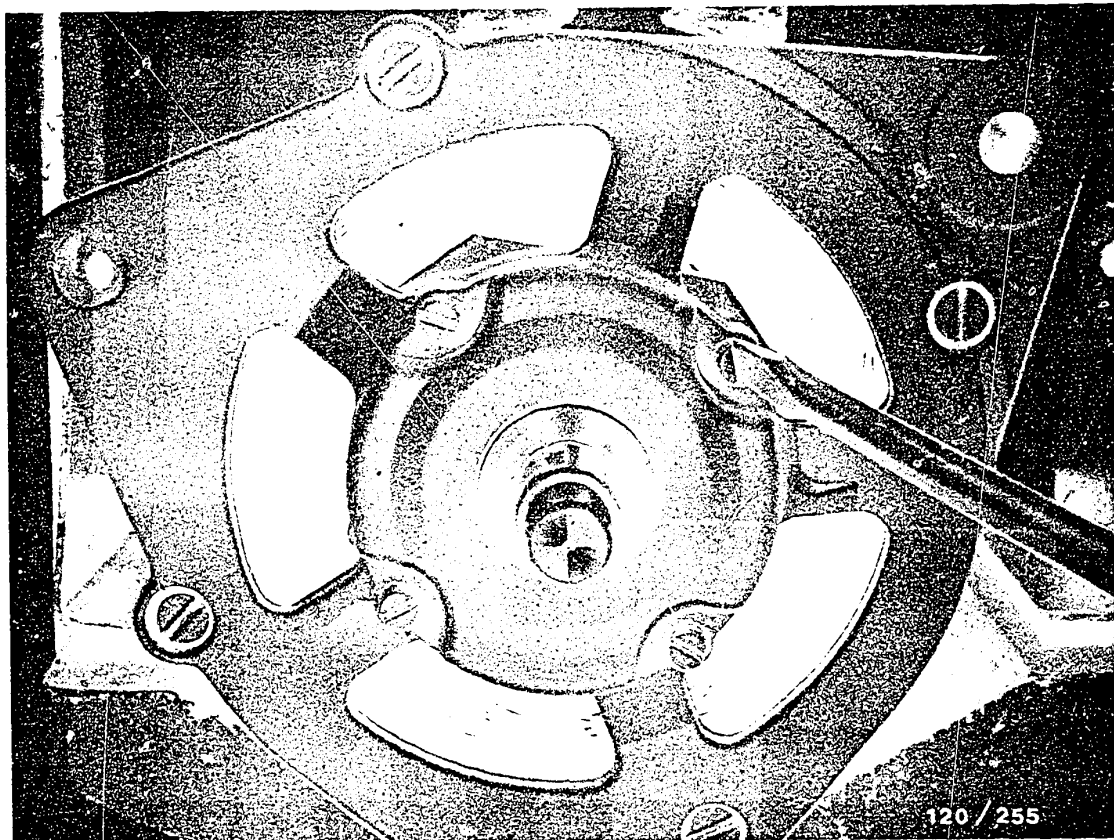

Removing the claw-pole rotor

Claw-pole rotor need only be removed if the following parts are defective:

Collector rings, excitation winding or deep-groove ball bearing.

Loosen 4 fastening screws and remove (see picture).

Pull deep-groove ball bearing with rotor out of bearing end plate (sliding fit).

B 12

Dismantling the alternator

Alternators 0 120 4.., 28V



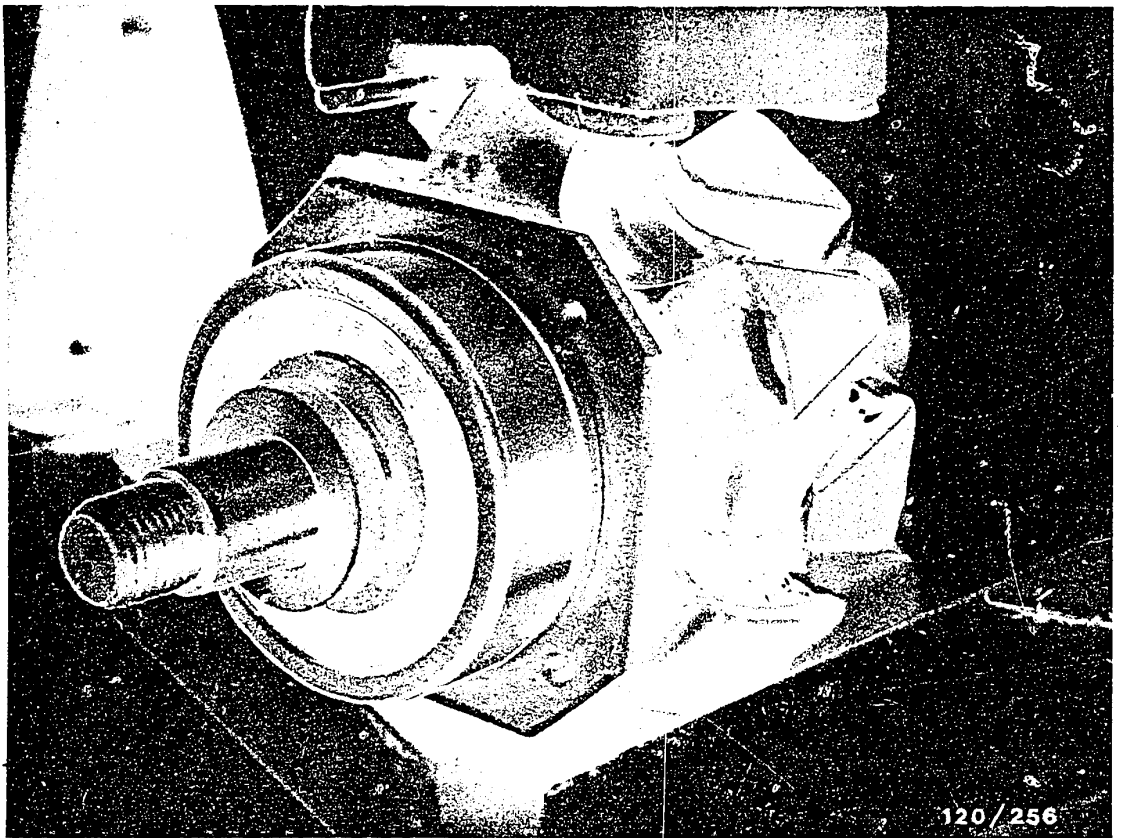

Clamp the claw-pole rotor in the clamping support.

Using a commercially available puller, pull off the deep-groove ball bearing with cover plate.

B 13

Dismantling the alternator
Alternators 0 120 4..., 28V



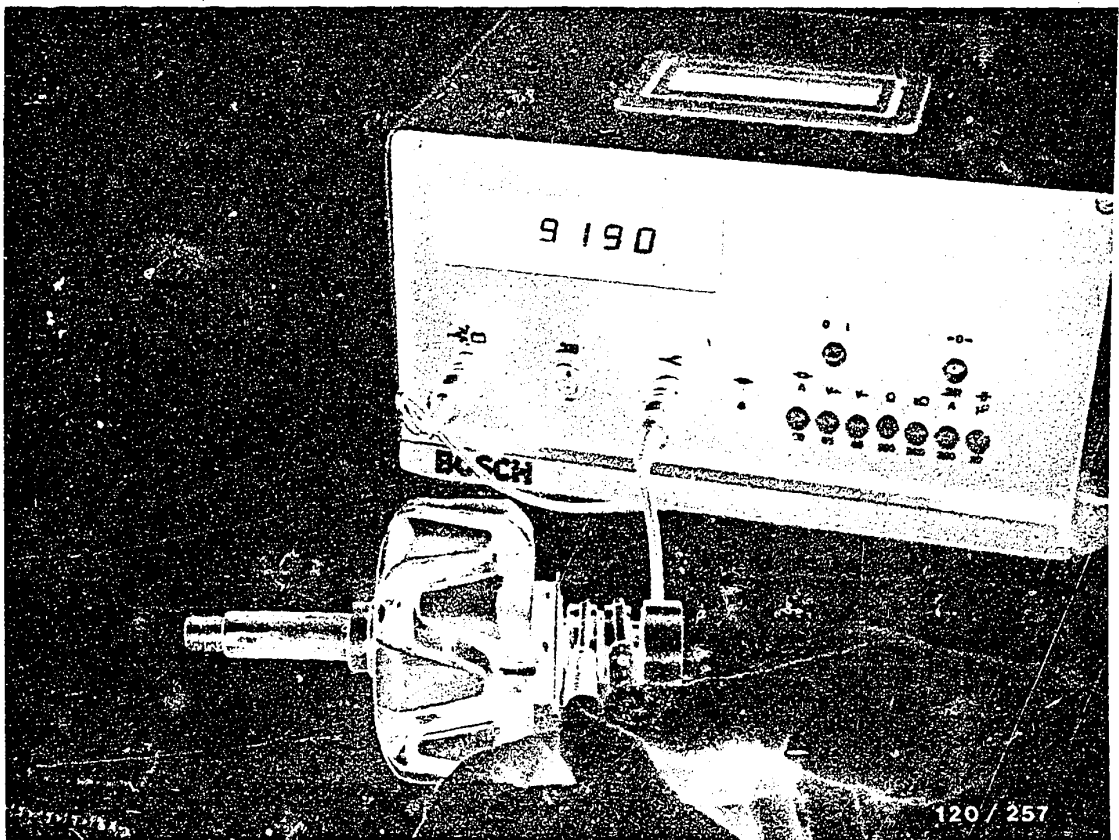

7.6 Testing the resistance of the rotor

Measure resistance of rotor using electric tester ETE 014.00 (see picture).

Resistance 9.0 ... 9.9 Ω .

B14

Dismantling the alternator

Alternators 0 120 4..., 28 V



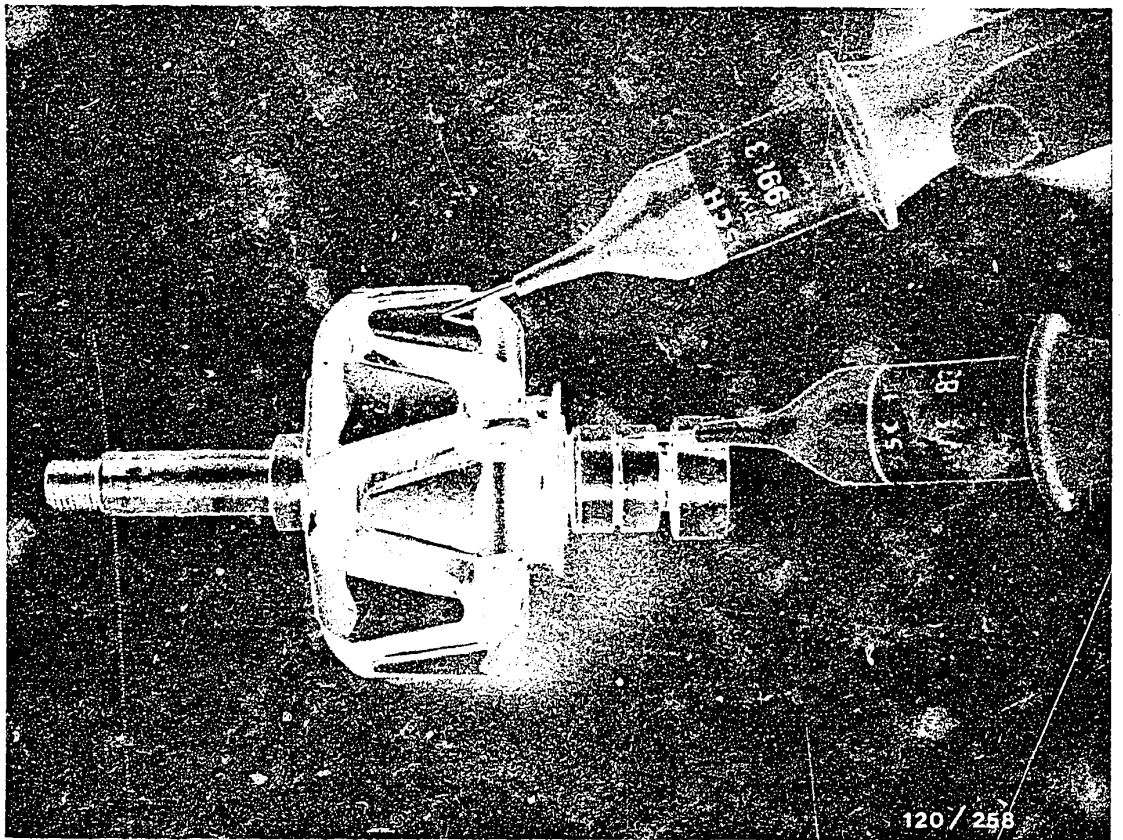

7.7 Testing the rotor for short circuit to ground

Test the rotor for a short circuit to ground using test prods EFAW 84 or KDAW 9983.
Test voltage 80 V AC.

B15

Dismantling the alternator

Alternators 0 120 4..., 28 V



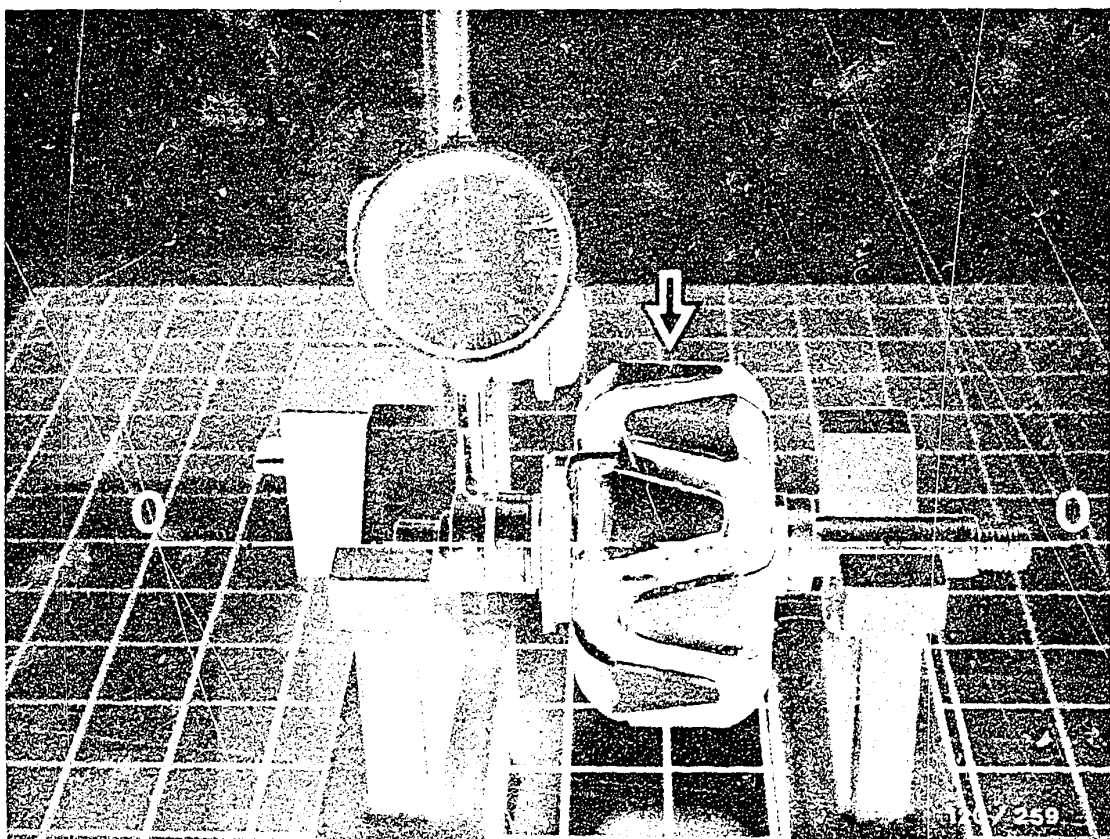

7.8 True-running test

Mount the journals of the rotor in the V-supports and align exactly horizontal. Carry out true-running test on outside diameter of rotor (see picture, arrow) and on outside diameter of the collector rings using magnetic instrument stand T-M1 (4 851 601 124) and dial indicator EFAW 7.

Maximum error on rotor 0.05 mm.

Maximum error on collector rings 0.03 mm.

If error is greater, skim collector rings.

Minimum diameter of collector rings 26.8 mm.



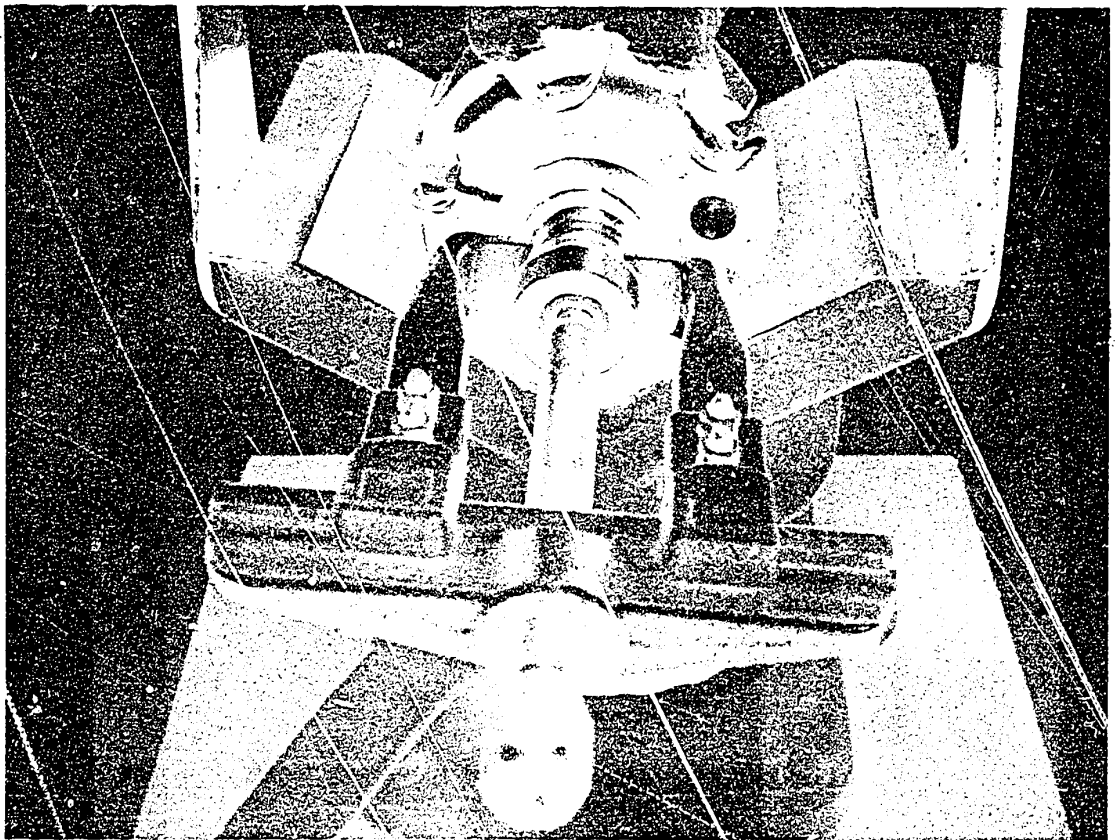

Removing the collector rings

Pull off inner race of cylindrical-roller bearing using commercially available puller (see picture).

Unsolder leads of excitation winding from the collector rings. Using commercially available puller, remove the collector rings from the rotor shaft (not shown).

B17

Dismantling the alternator

Alternators 0 120 4..., 28 V



8. Cleaning the parts

CAUTION! FIRE HAZARD!

Alternators are being increasingly fitted with long-storage capacitors (e.g. for the interference suppression of receivers and transmitters).

When washing parts of the alternator it is possible for the capacitor to discharge when immersed in cleaning fluids, there then being the danger that inflammable liquids will ignite. For this reason, parts with capacitors must only be washed in tri- or perchloro-ethylene.

B18

Dismantling the alternator

Alternators 0 120 4 ..., 28 V





9. Assembling the alternator

Pressing on the collector rings

Place the collector rings on the rotor shaft. Introduce one lead from the excitation winding into the groove in the collector rings. Then press on collector rings as far as they will go using press-on tool KDLJ 6012. When doing this, position the groove of the press-on tool so that the lead of the excitation winding which is guided through the collector rings is visible.

Solder the wire leads of the excitation winding. Turn down the soldered joint on both collector rings until the collector rings are no longer uneven.

C1

Assembling the alternator

Alternators 0 120 4 ... 28 V



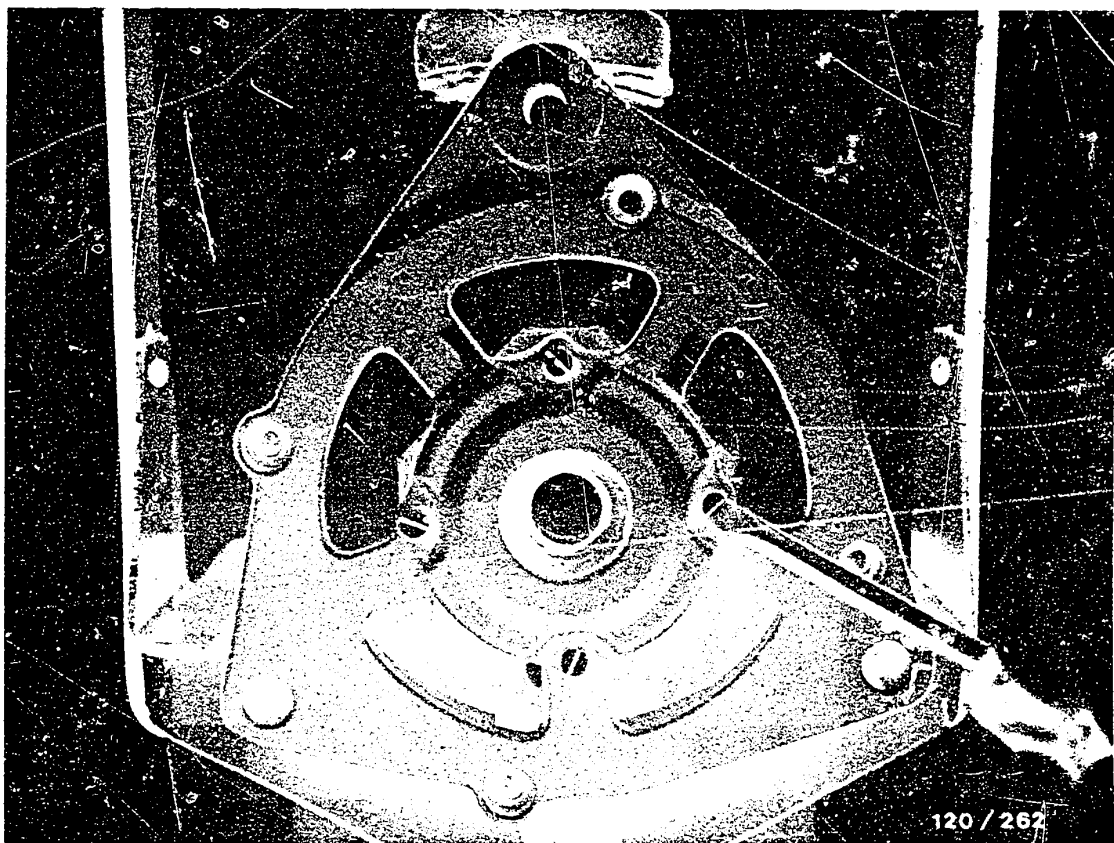

Assembling the drive end shield

Insert deep-groove ball bearing in drive end shield.
Position cover plate on inside of drive end shield.

Screw on cover plate from outside with 4 screws.
Tightening torque 2.2...2.9 Nm.

C2

Assembling the alternator

Alternators 0 120 4..., 28 V



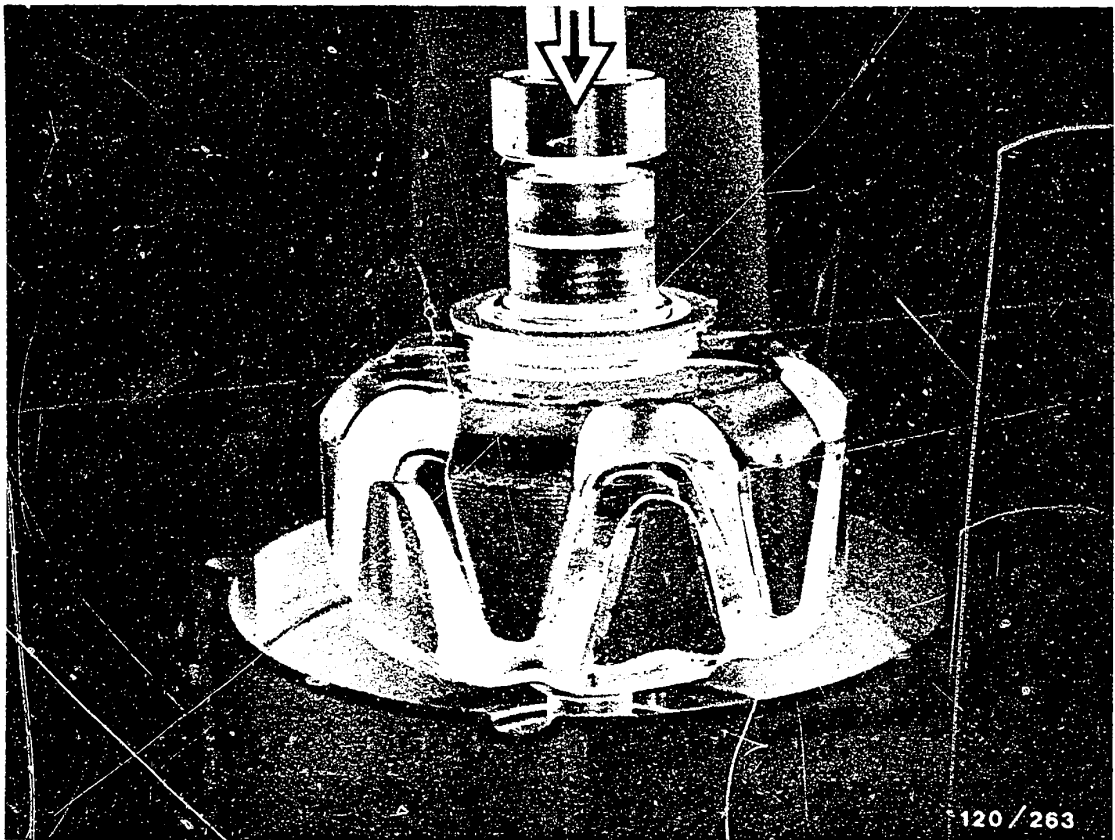

Pressing the rotor into the drive-end-bearing housing

Insert a spacer ring in the drive-end-bearing housing on the fan side, with the narrow collar to the deep-groove ball bearing. Lay the drive-end-bearing housing with spacer ring on a suitable support surface so that, when the rotor is pressed in, no pressure is exerted on the end shield.

Introduce the rotor into the deep-groove ball bearing (see picture).

Place the new deep-groove ball bearing (arrow) on the rotor shaft on the collector ring side. Using press-in mandrel KDLI 6002, press the deep-groove ball bearing and rotor as far as they will go into the drive-end-bearing housing.

C3

Assembling the alternator

Alternators 0 120 4..., 28V



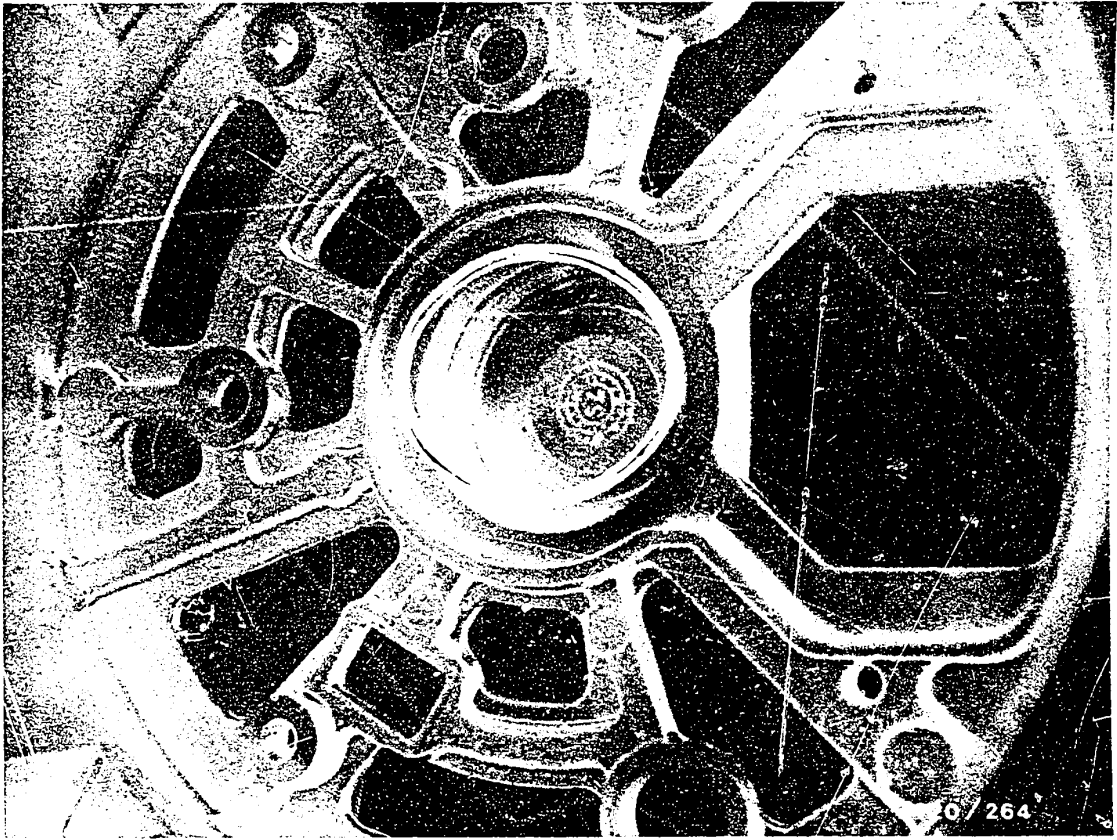

Replacing the O-ring

Examine the O-ring in the collector-ring end shield for damage. If necessary, replace with a new O-ring.

C4

Assembling the alternator

Alternators 0 120 4.., 28V



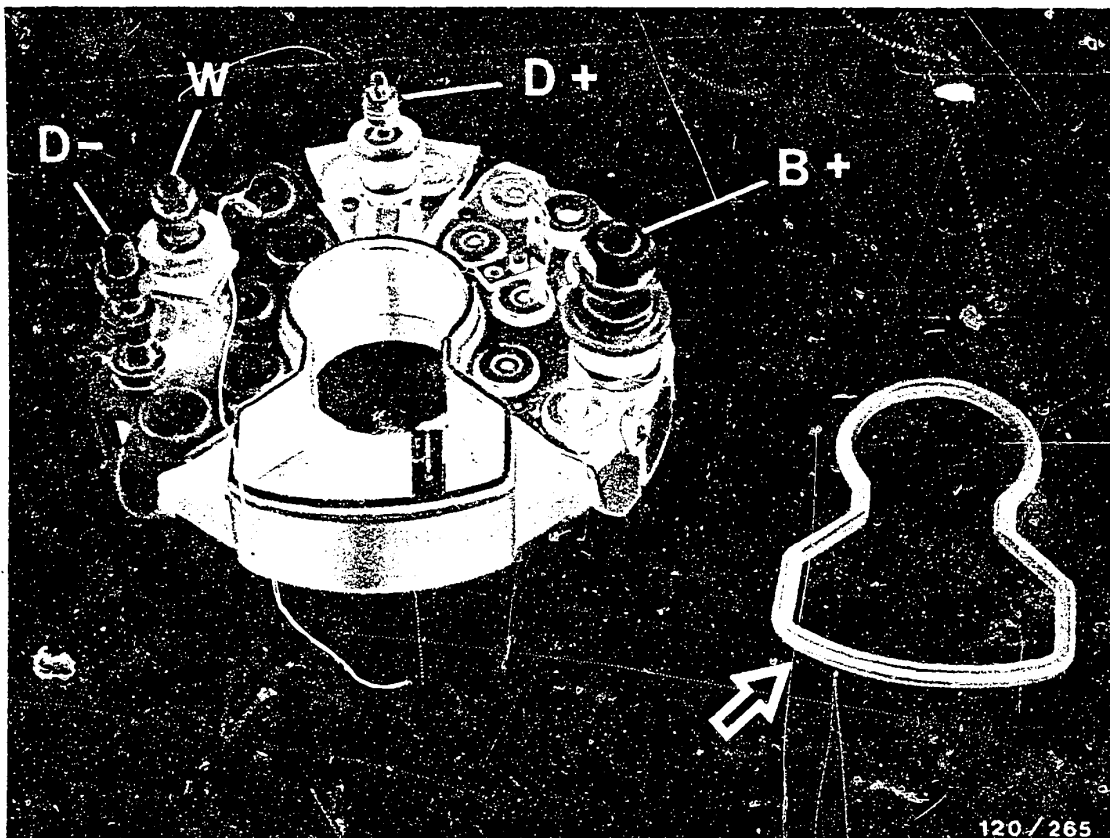

9.1 Installing the rectifier

Place seal (arrow) onto "keyhole"-shaped rim of rectifier and bond down all the way round using dispersion binder 5 703 151 000.

Place plain washer and insulating bushing over terminals B+ and D+.

Introduce rectifier into collector-ring end shield.

C5

Assembling the alternator

Alternators 0 120 4..., 28 V



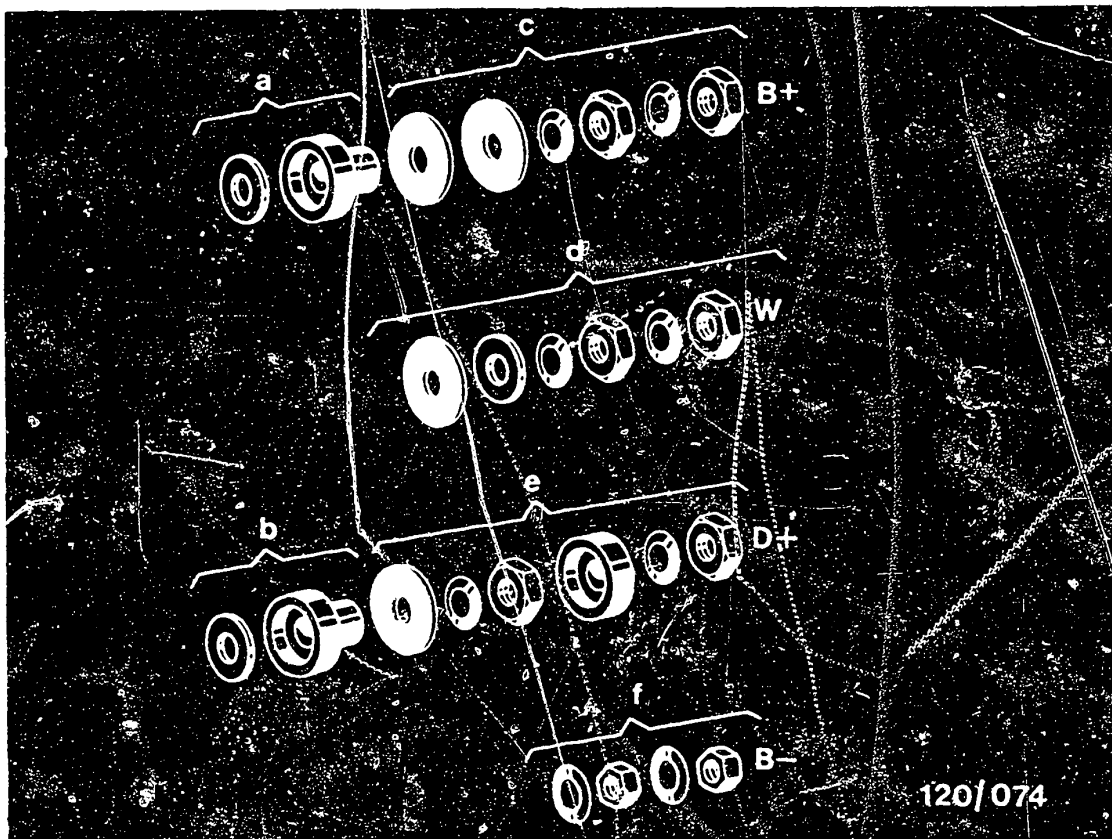

120/074

Fasten the rectifier at the terminal end using parts c, d, e, f.

Tightening torques:

Part c = 7.5 ... 8.0 Nm

Part d = 2.7 ... 3.8 Nm

Part e = 1.4 ... 2.0 Nm

Part f = 4.8 ... 6.8 Nm

C6

Assembling the alternator

Alternators 0 120 4.., 28 V



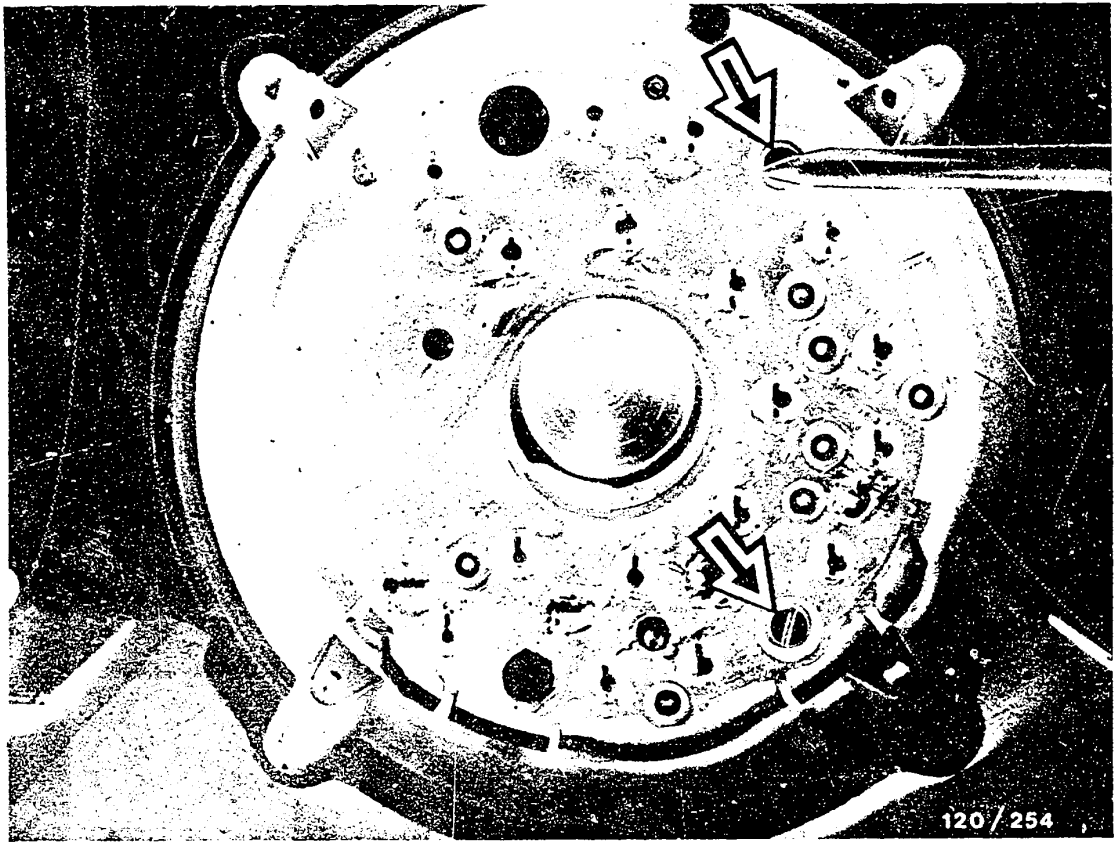

120 / 254

Screw down the rectifier on the generator end with 2 or 3 washer-and-screw assemblies (arrows) - depending on the alternator model.

Tightening torque: 1.4 ... 2.0 Nm

C7

Assembling the alternator

Alternators 0 120 4.., 28 V



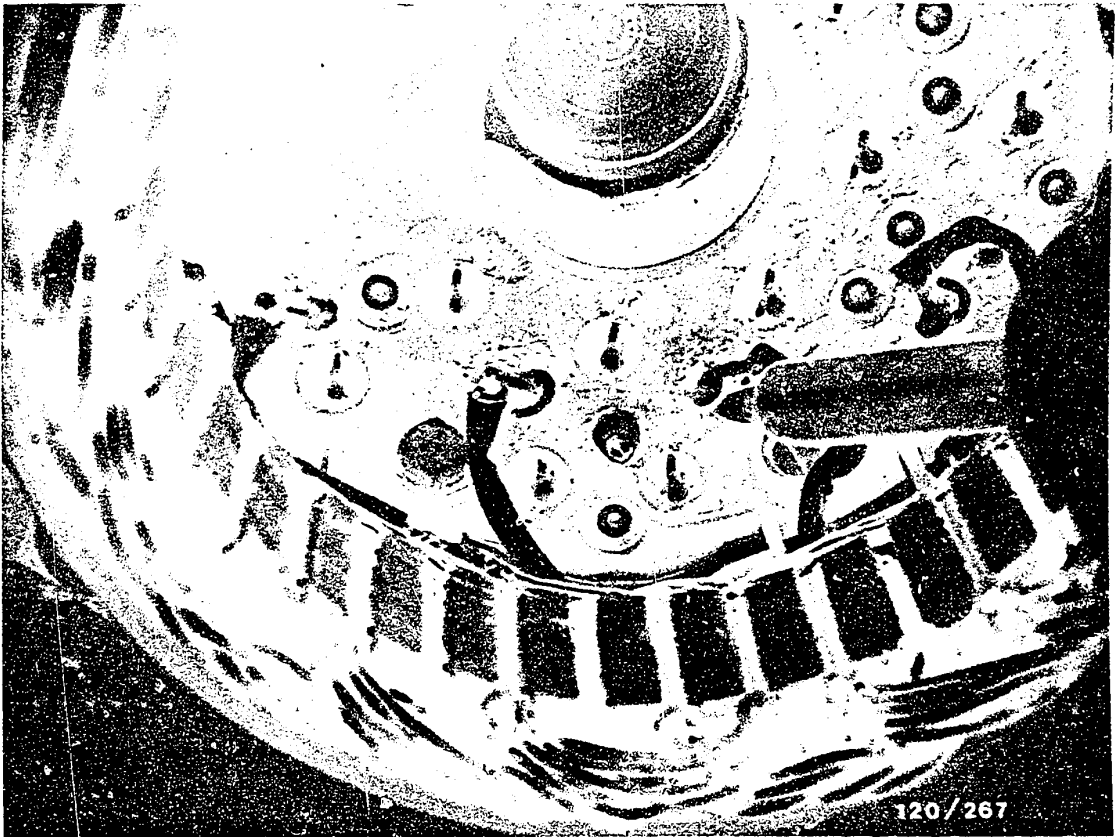

9.2 Fitting the stator and the rotor

Place the stator against the rectifier bearing. Bring the markings on the collector-ring end shield and stator (made before dismantling the alternator) into alignment.

Solder on the connection wires of the stator (see picture). When doing this, make sure that the connection wires will not afterwards touch against the rotor. Carefully introduce rotor with drive end shield.

Note:

Do not use too much solder, otherwise there is the danger of short-circuits.



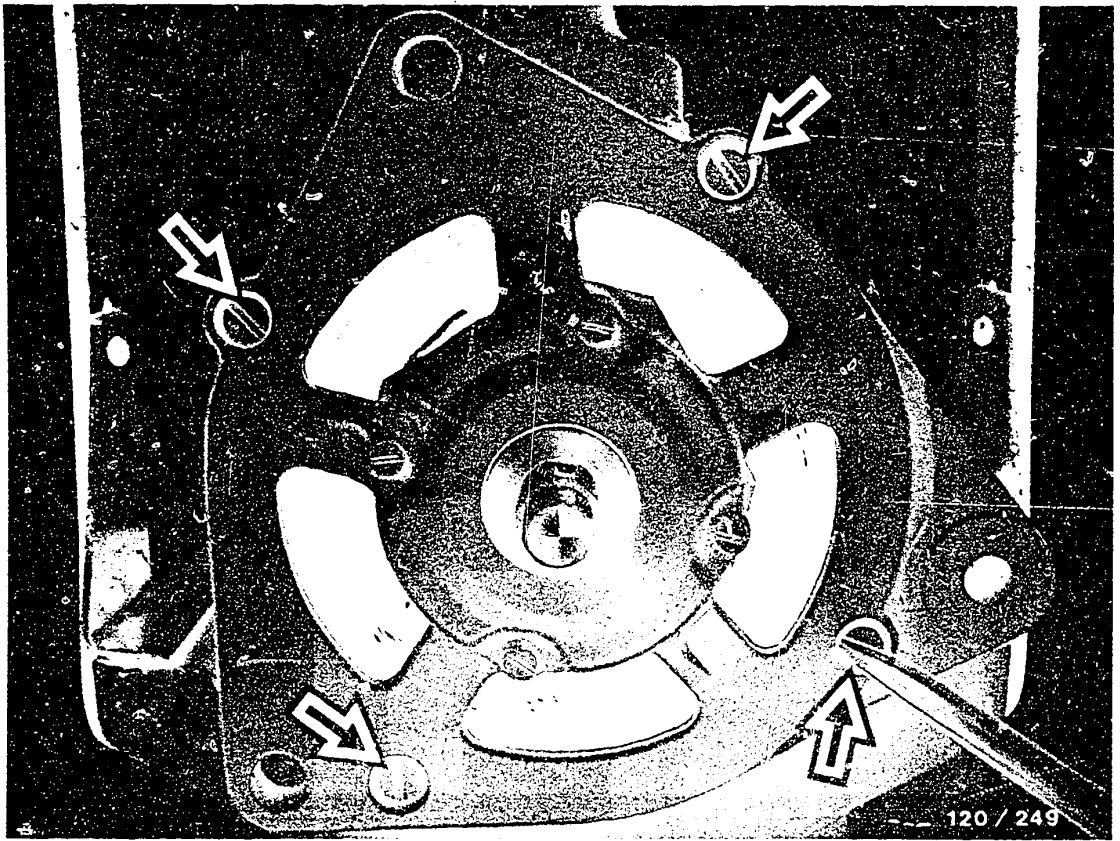

The following operations are necessary in order to obtain correct true-running of the rotor and alignment of the drive-end-bearing housing with the collector-ring end shield:

Insert three feeler gauges between stator and rotor; thickness 0.2mm.

Using a screwdriver, position 4 fillister-head screws (arrows), then tighten cross-wise to torque of 4.1 ... 5.5 Nm.

C9

Assembling the alternator
Alternators 0 120 4.., 28V



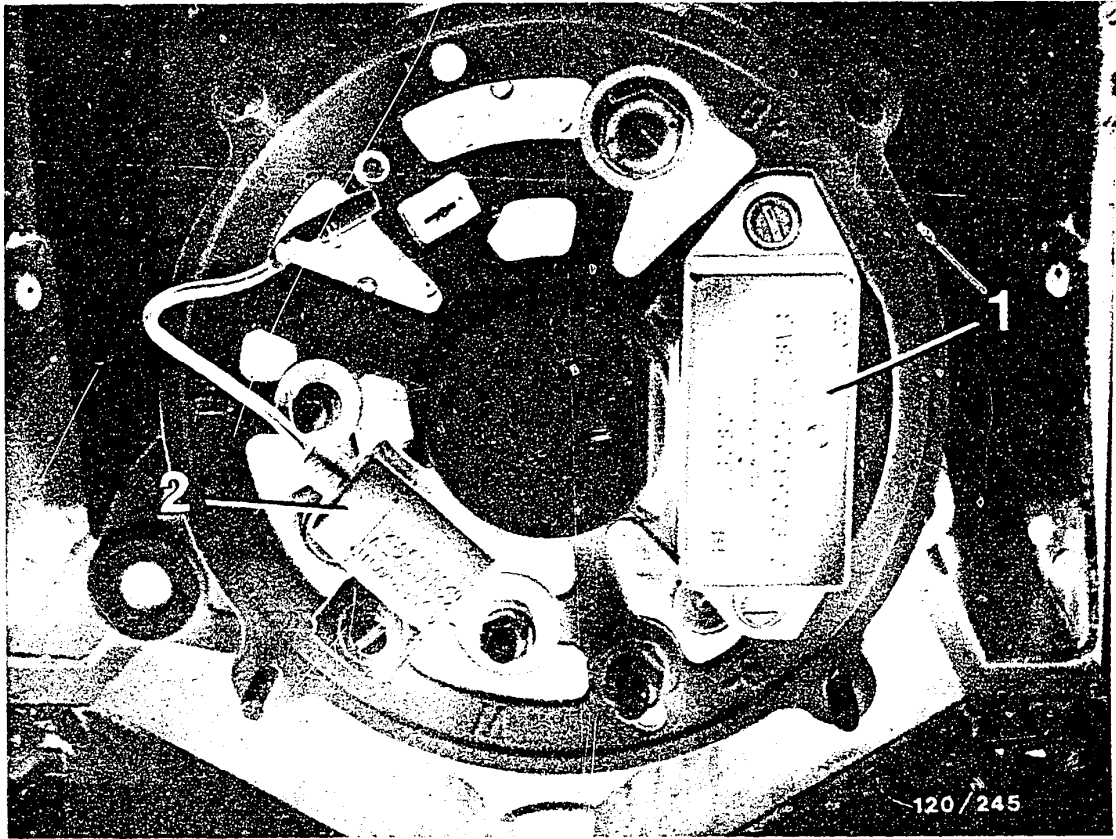

- 1 = Transistor regulator with brush holder
- 2 = Suppression capacitor

9.3 Installing the regulator and suppression capacitor

Swing the regulator into the collector-ring end shield and screw on with fastening screws (picture).

Tightening torque: 1.6 ... 2.3 Nm

Screw on the suppression capacitor (picture).

Tightening torque: 1.4 ... 2.0 Nm

Plug the connector of the suppression capacitor onto B+ terminal.



10. Testing the alternator with regulator on the test bench

10.1 Test equipment and devices

Alternator test bench	EFLJ 91	0 683 300 100
	or EFLJ 25..	0 680 110 ..
	or EFLJ 70 A	0 680 104 ..
or combination test bench (only for loading up to max. 43 A)	EFAW 275 ..	0 681 107 ..
Mounting plate for mounting swivel-arm-mounted alter- nators on alternator test bench	EFLJ 66/3	
	EFLJ 25, 70	
Parts set for mounting swivel-arm- mounted alternators on combination test bench	EFAW 275 ..	1 687 000 042
Alternator tester	WPG 012.00	0 681 101 403
For additional test:		
Ignition oscilloscope	(all models)	
or		
Bosch Motortester	(all models)	

D1

Testing

Alternators 0 120 4.., 28 V



Mounting on the test bench

Swivel-arm-mounted or flange-mounted alternators must only be mounted on the test bench using the appropriate clamping fixture.

So that the power of the test-bench motor is sufficient, only test using the appropriate fan and pulley. Select the correct transmission ratio.

For test bench EFLJ 25 .. the transmission ratio is 0.3:1. This means: If the alternator pulley is, for example, 100 mm \emptyset , use test-bench pulley with 350 mm \emptyset .

For test bench EFLJ 70 A the transmission ratio is 0.4:1. This means: If the generator pulley is, for example, 100 mm \emptyset , use test-bench pulley with 250 mm \emptyset .

Note: If, at very high alternator outputs, the drive power of the test-bench motor is not sufficient, then only carry out the test to the extent that the test speed does not drop at the required test current.

The charge indicator lamp must be completely out when power-testing.

D2

Testing

Alternators 0 120 4 .., 28 V



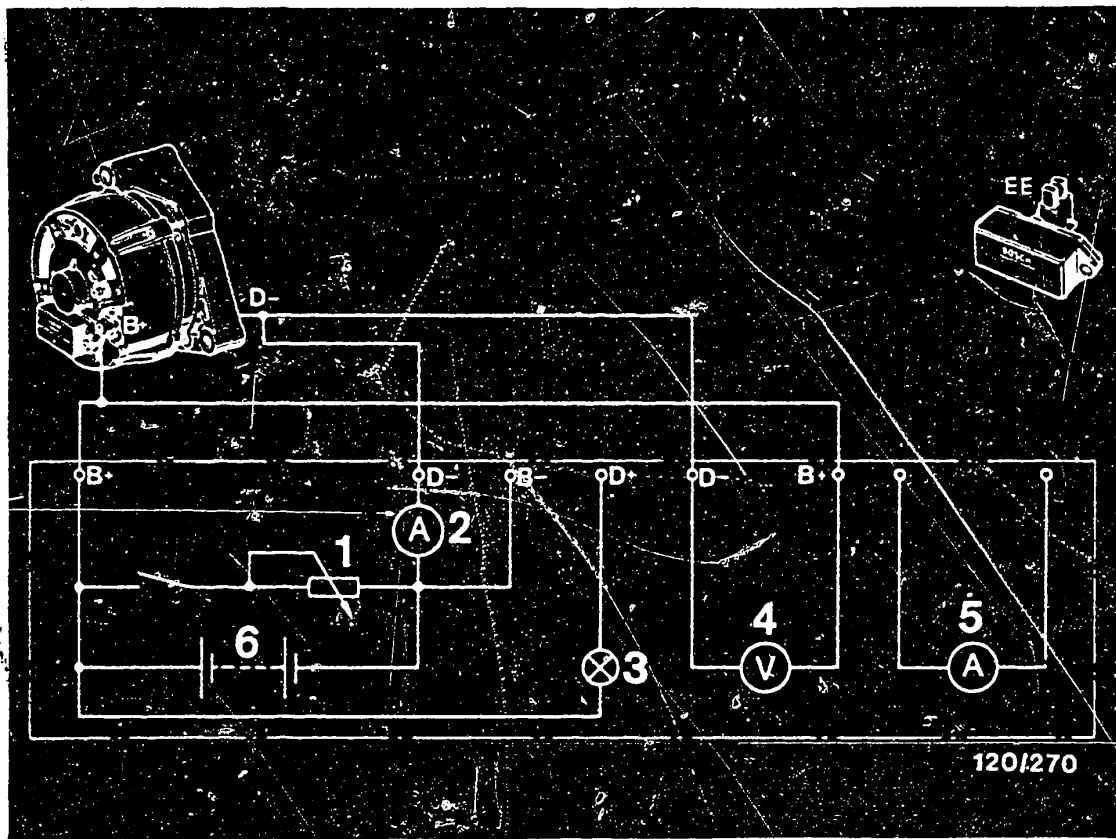

120/270

- 1 = Loading resistor 4 = Voltmeter (regulated voltage)
 2 = Ammeter 5 = Ammeter
 3 = Indicator lamp 6 = Test-bench battery

Connecting the alternator to the test bench

Connect the positive battery cable of the test bench to B+ of the alternator.

If the clamping table on the test bench is used as a ground cable, make sure that there are no contact resistances. It is therefore advisable in the case of high-power alternators to connect the negative battery cable of the test bench directly to the alternator. Connect voltmeter between B+ and B-.

D3

Testing

Alternators 0 120 4 .., 28 V



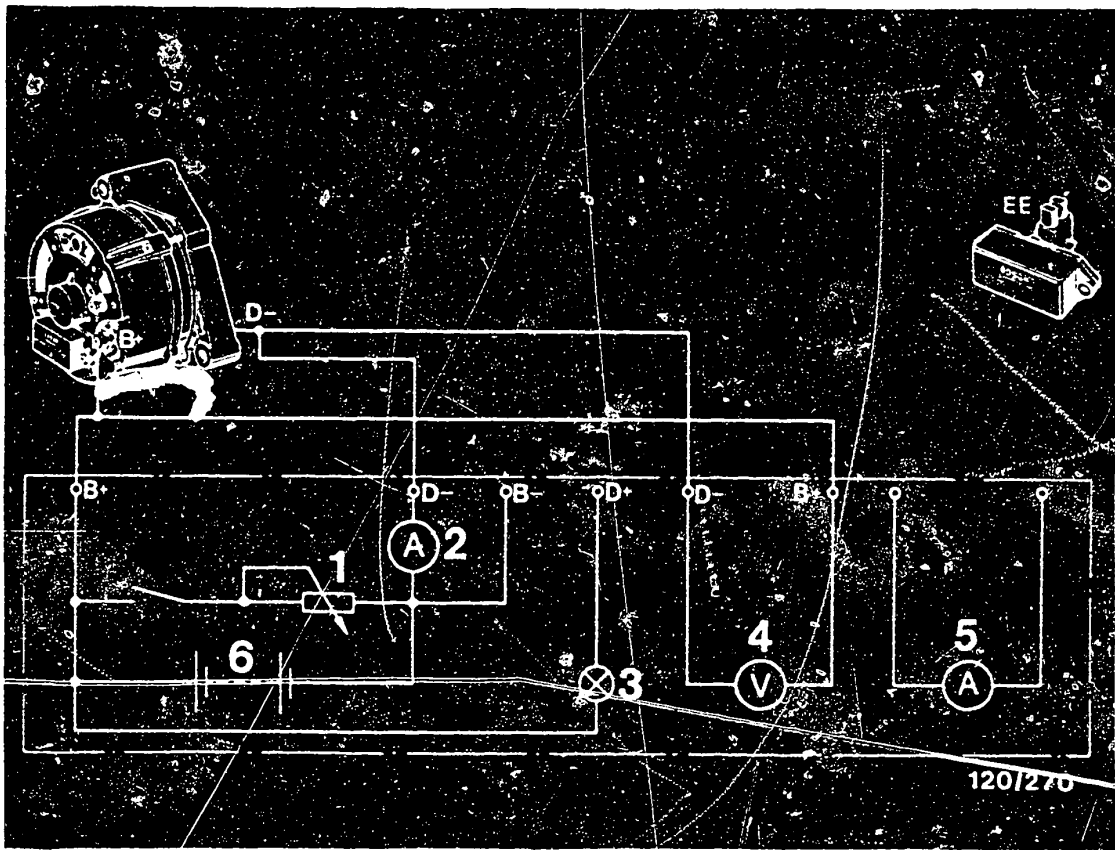

- | | |
|----------------------|-----------------------------------|
| 1 = Loading resistor | 4 = Voltmeter (regulated voltage) |
| 2 = Ammeter | 5 = Ammeter |
| 3 = Indicator lamp | 6 = Test-bench battery |

Important:

All connections on the test bench must be properly made. When the alternator is running the connection between alternator and battery must not be disconnected since, otherwise, the semiconductors in the alternator and regulator may be destroyed.

Do not operate the alternator without the battery being connected.

If a direction of rotation is marked on the fan wheel or on the alternator, then the alternator must only be driven in this direction of rotation.



Power test

Note: For the power test ensure that the current-reducing resistor installed in the test bench is not connected into the circuit since, otherwise, the charge indicator lamp will glow and make it look as if there is a fault in the alternator.

For testing, bring the alternator up to operating temperature (approx. 60°C) on the test bench. To do this, select a speed of 2000 min⁻¹.

Power test with regulator

Set the regulated voltage at the alternator to 26V. Then bring the alternator to the stated test speed and adjust the loading resistance until the stated current is obtained. The indicated voltage must not drop below the alternator voltage.

Alternator O 120 4..., N1 (RL) 28V55A25

Alternator speed min ⁻¹	Load current A
1450	10
2500	36
6000	55

Regulated voltage 27.6 ... 28.4V
at load current \leq 10A
and test speed = 6000 min⁻¹

D5

Testing
Alternators O 120 4..., 28V



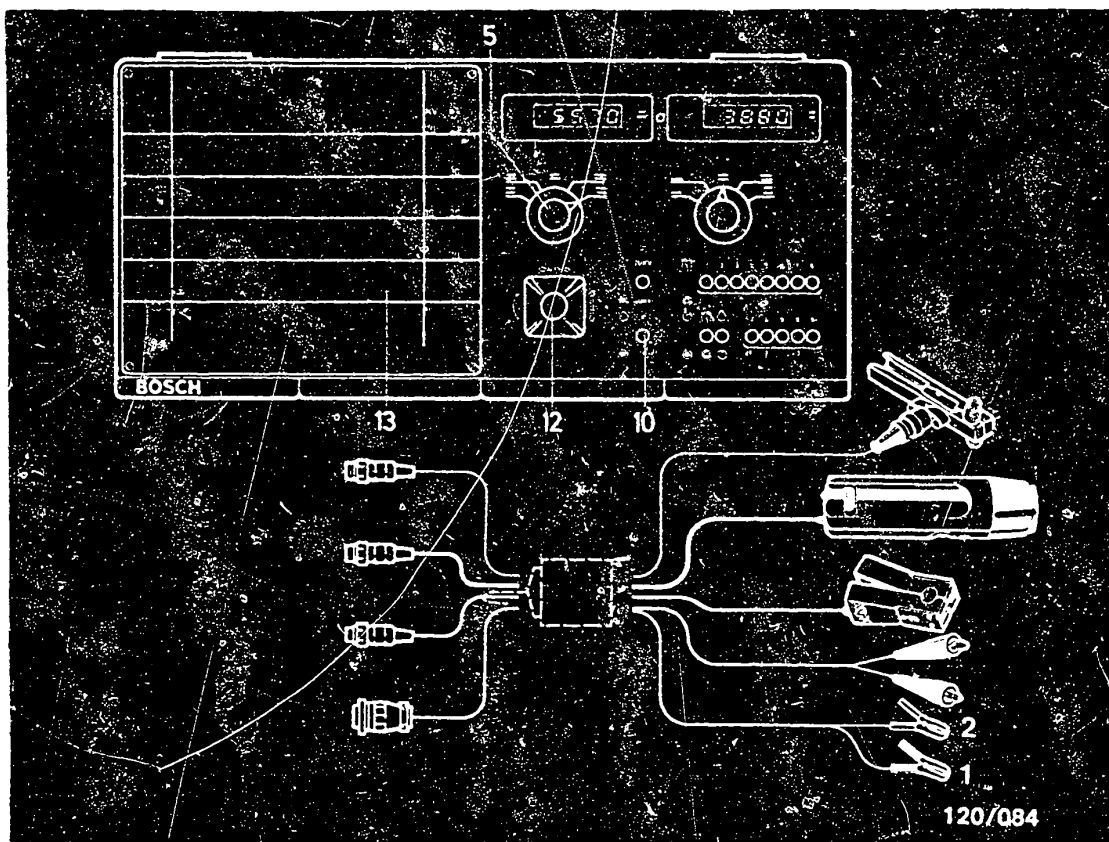

10.2 Testing with the oscilloscope

Connect oscilloscope (MOT 002.00) to the alternator using corresponding test lead.

Red clip (1) to terminal D+.

Black clip (2) to terminal B- (ground).

D6

Testing

Alternators 0 120 4 .., 28 V



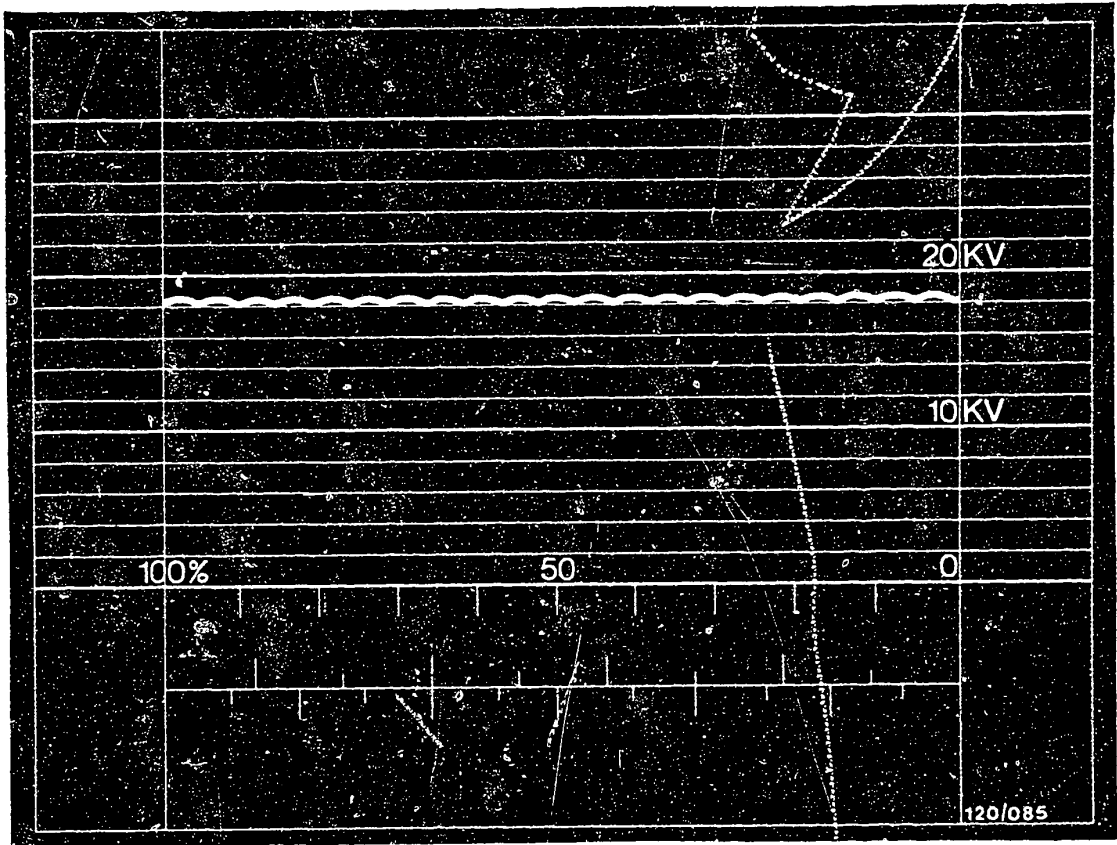

Adjusting and evaluating the oscilloscope displays

If the alternator is in proper working order, the above display is obtained. The DC voltage supplied has a slight ripple content. The oscilloscope display may have small spikes superimposed on it when the regulator is in operation. The regulator can be "shut down" by connecting in a load (e.g. loading resistor).

Adjust the height of the display so that the ripple content is between two kV lines.

In order to compare such displays, the respective display must be adjusted using the vertical controller of the oscilloscope so that it more or less fits in between the 10 and 20 kV lines.

Note: It is also possible for several defects to occur together.

D7

Testing

Alternators 0 120 4 .., 28 V



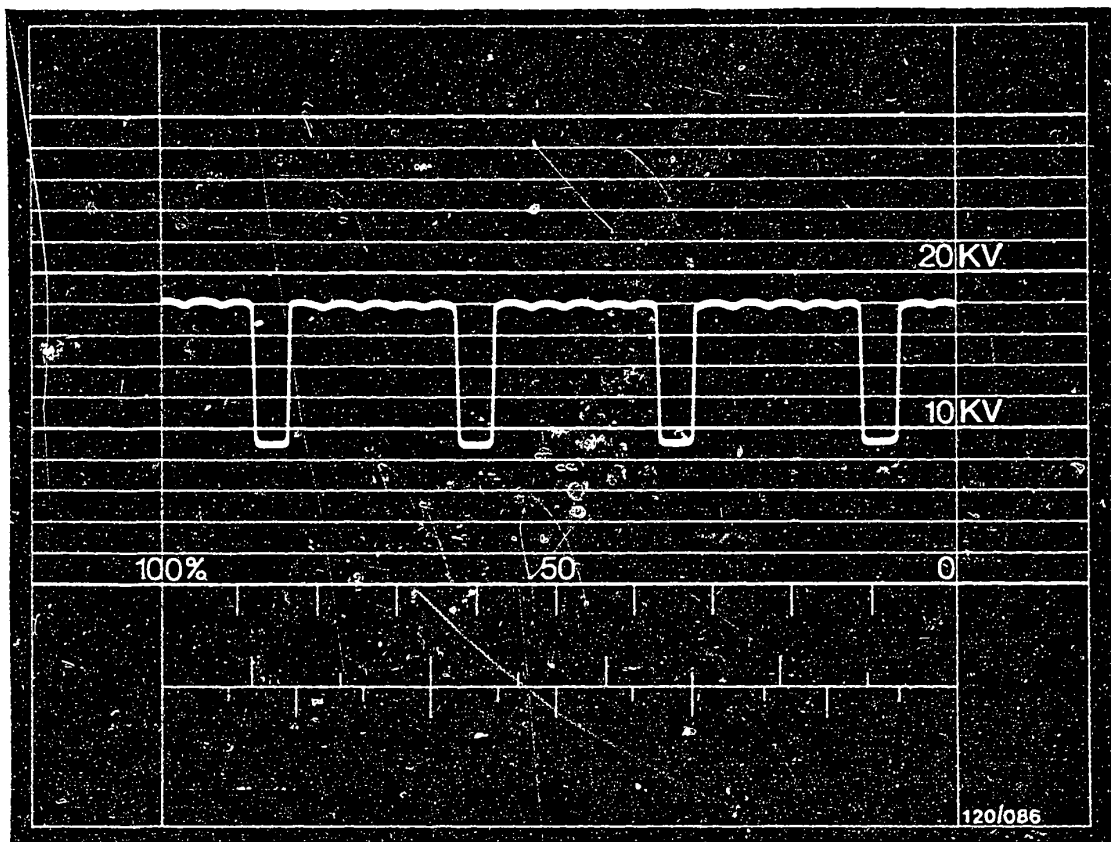

Oscilloscope display shows open circuit in an exciter diode.

D8

Testing

Alternators 0 120 4 ..., 28 V



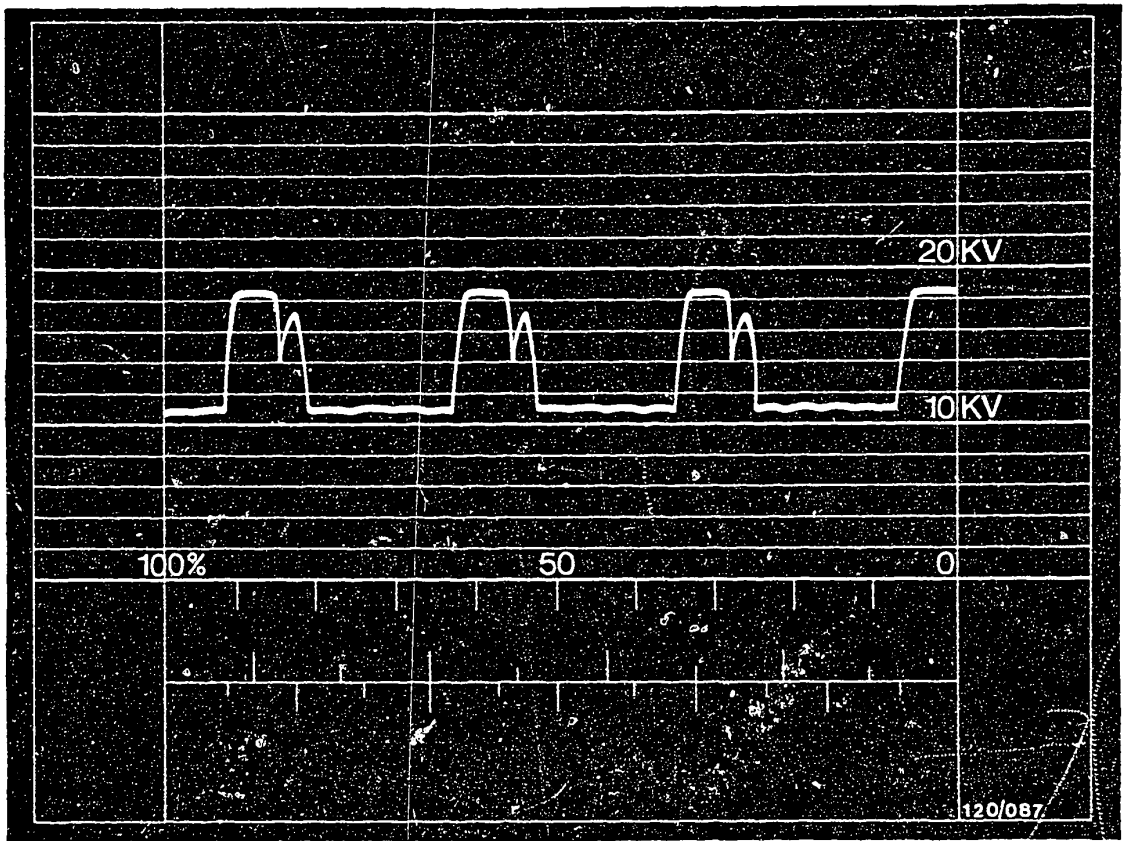

Oscilloscope pattern shows open circuit of a positive diode.
If several diodes are connected in parallel in an alternator, then this oscilloscope pattern only appears if all diodes have an open circuit.



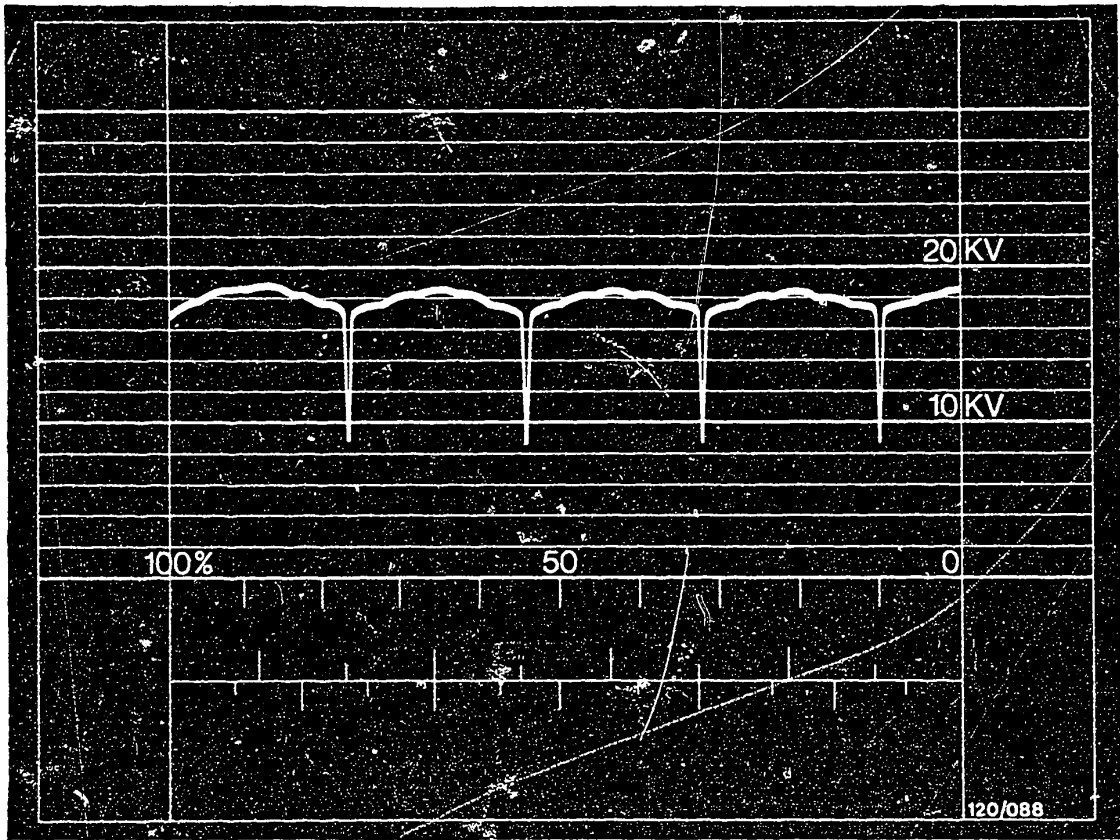

Oscilloscope pattern shows open circuit of a negative diode.

If several diodes are connected in parallel in an alternator, then this oscilloscope pattern only appears if all diodes have an open circuit.



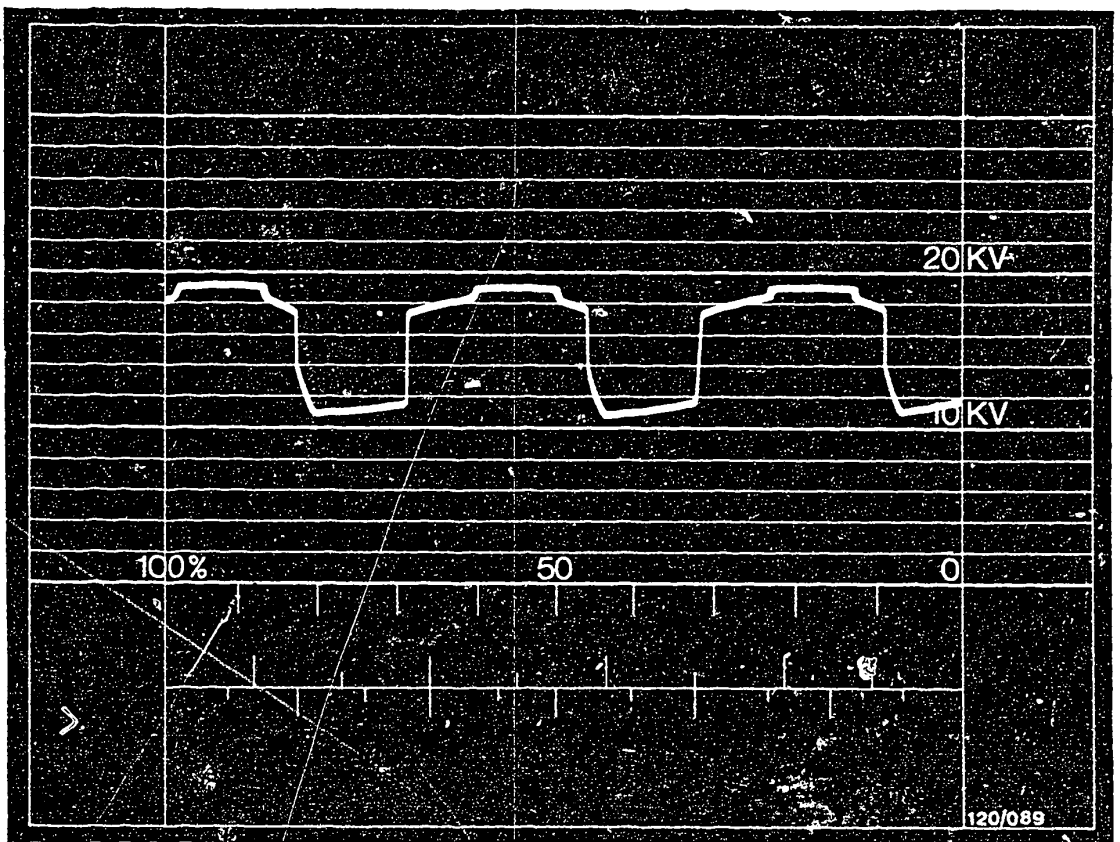

Oscilloscope display shows short circuit in a positive diode

D11

Testing

Alternators 0 120 4 .., 28 V



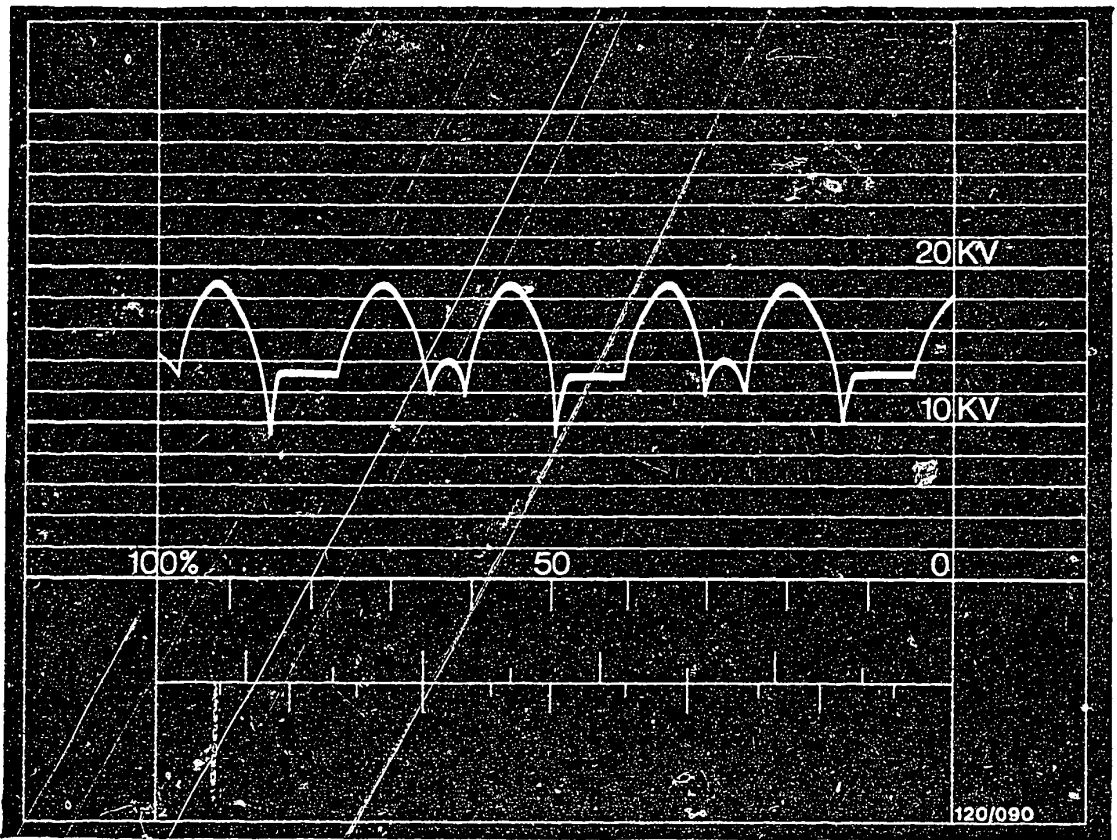

Oscilloscope pattern shows short circuit of one or more positive diodes.

D12

Testing
Alternators 0 120 4.., 28V



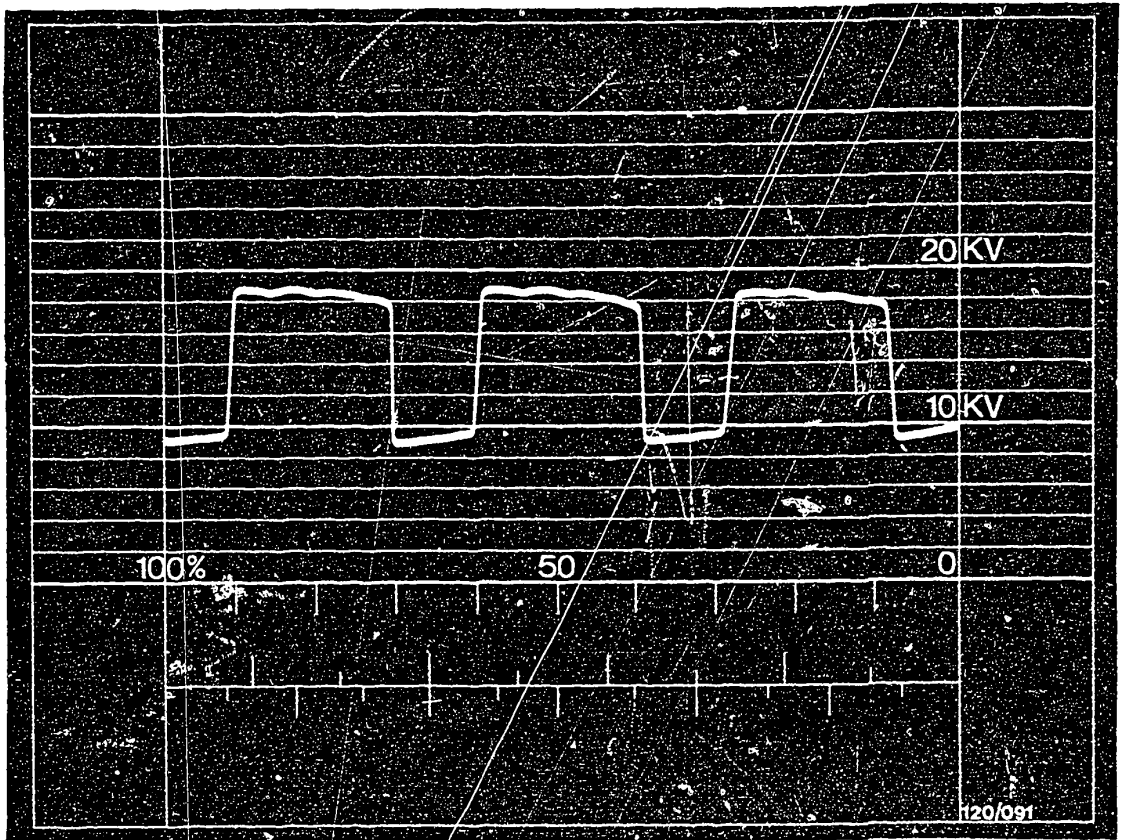

Oscilloscope pattern shows short circuit of one or more negative diodes.

D13

Testing

Alternators 0 120 4.., 28V



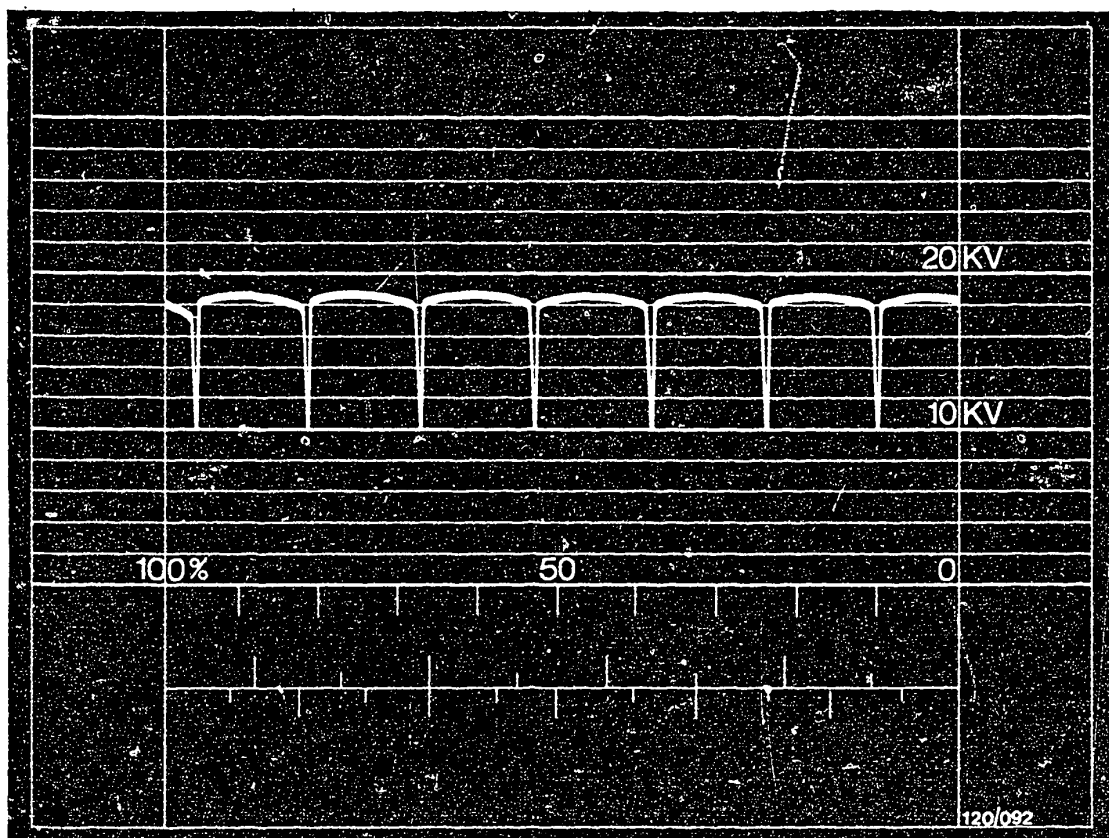

Oscilloscope display shows phase defect (open circuit)

D14

Testing

Alternators 0 120 4 ..., 28 V



After-sales Service

Technical Bulletin

Only for use within the Bosch organization. Not to be communicated to any third party.

Parts Cleaning

Use of highly-inflammable cleaning agents, or cleaning agents which are dangerous to health

Gen.

VDT-I-Gen./18 En
7. 1978

When cleaning parts which come from vehicle electrical products prior to repair, it is permitted to use the following cleaning agents: Benzine, trichloroethylene (tri) and perchloroethylene (per). These are dangerous, and must be handled with appropriate care. The relevant safety regulations in West Germany are:

Regulations concerning work with inflammable liquids (VbF) issued by the Federal Labor Ministry (BmA).

Safety regulations for the use of chlorinated hydrocarbons
as applied to the works ZH1/222
as applied to personnel ZH1/119

as issued by the Federation of the Trade co-operative Associations (Central Association for Accident Prevention and Industrial Medicine) Langartweg 103, D-5300 Bonn 5).

1. Benzine, acetone and ethanol (ethyl alcohol) are inflammable liquids and their mixtures with air are dangerous due to the risk of explosion. Parts washing may only take place in tanks or containers solely intended for this purpose and equipped with a "melt" safety device for the lid which, in case the liquid catches fire, causes the lid to close automatically and smother the fire. In the case of larger containers (exceeding 500 x 500mm) some form of suction extraction must be provided.
- 1.1 Generators, alternators, wiper motors, small-power motors and other electrical equipment for installation in vehicles are, in ever increasing numbers, being equipped with capacitors having long storage times (e.g. for interference-suppression purposes in radio-receiver or transmitter installations).

When washing such parts, it is possible that a capacitor discharge can occur when the part is immersed in the cleaning agent. This can lead to an inflammable liquid catching fire. For this reason, parts on which a capacitor is fitted are only to be washed in trichloroethylene (tri) or perchloroethylene (per).

- 1.2 In the case of starting motors, it has already been pointed out in earlier repair instructions that the parts should be thoroughly dried after washing in benzine, this applies particularly to windings. With sliding-gear starting motors, the first test run after washing out must be performed without the closure cap in order to avoid the possibility of explosion.

BOSCH

Geschäftsbereich KM Kundendienst, Kfz-Ausrüstung
© by Robert Bosch GmbH, D-7 Stuttgart 1, Postfach 50. Printed in the Federal Republic of Germany.
Imprimé en République Fédérale d'Allemagne par Robert Bosch GmbH.

L1

Technical Bulletin

Alternators 0 120 4.., 28 V



2. Trichlorethylene (tri) and perchloroethylene (per) are both liquids whose vapors have a stupefying effect, and which are dangerous to health if inhaled over long periods. Tri vapor is heavier than air, and therefore especially dangerous at floor level. Gloves and goggles are to be worn when washing out parts in these liquids.

If cleaning of parts is carried out regularly, or continuously, in trichlorethylene only containers or tanks intended solely for this purpose are to be used, and the suction extraction device is to be switched on. When washing parts do not bend over the container.

L2

Technical Bulletin

Alternators 0 120 4... 28 V



After-sales Service

Technical Bulletin

Only for use within the Bosch organization. Not to be communicated to any third party.

Sheet Steel Fans for Alternators of Sizes G and K

12

VDT-I-120/103 B
9.1976

Fan discs, primarily produced from galvanized sheet steel, are subjected to varying loads during operation, the magnitude of which depends on the driving habits of the operator.

Please note that, as a safety measure, when repairing or replacing alternators that have been used for more than 100,000 km or for 2,000 operating hours, new sheet-steel fan discs should be installed.

When doing this, be sure that the direction of rotation of the fan disc, as well as the sequence and position of accessories, are correct.

Tightening torque for the fastening nut: 35 - 45 Nm.

In case of inquiry, please contact your authorized representative.

BOSCH

Geschäftsbereich KM, Kundendienst, Kfz-Ausrüstung
© by Robert Bosch GmbH, D-7 Stuttgart 1, Postfach 50. Printed in the Federal Republic of Germany.
Imprimé en République Fédérale d'Allemagne par Robert Bosch GmbH.

L3

Technical Bulletin

Alternators 0 120 4..., 28 V



After-sales Service

Technical Bulletin

Only for use within the Bosch organization. Not to be communicated to any third party.

Steel sheet fan wheels for alternators

Assembly instructions

12

VDT-I-120/103 B

Suppl. 1

7. 1977

Summary

When assembling the fan wheel and pulley, attention is to be paid to the correct sequence and position of the accessories, in particular the new supporting plate. See Figs. 1 ... 4 for assembly examples.

Details

Since the end of 1976 supporting plate 1 120 140 009 has been mounted between the fan and pulley assembly within the scope of further development for various alternators provided with steel sheet fan wheels.

The outside diameter of this new supporting plate (item a) is 55 mm. The 5 mm wide and approx. 0.3 mm high stamping on the rim presses against the fan. A slotted washer (item b) or the pulley itself is mounted directly on the side facing the pulley, depending on the alternator model. Care is to be taken that the 26 mm diameter collar of the slotted washer or pulley presses against the supporting plate.

In the case of steel sheet pulleys a second slotted washer (item c) is mounted between the pulley and spring lock washer. The spring lock washer or spring washer, as well as the fastening nut remain unchanged.

The tightening torque for the entire assembly continues to be 35 ... 45 N.m (approx. 3.5 ... 4.5 kgf.m).

Tool KDLJ 6006 is required to hold the pulley when tightening the nut.

Under no circumstances should the fan wheel be locked using a screwdriver or similar. Bent or damaged fan blades result in damage to the alternator.

In the case of alternators which are provided with the supporting plate ex-works, this plate must also be installed when repair work is performed. Basic information regarding use is provided by the service part documents and packing notes for service part packages. Supporting plate 1 120 140 009 is included in the scope of delivery of the pulley.

The complete assembly is matched to the alignment of the V-belt. Modifications or assembly errors may cause damage.

BOSCH

Geschäftsbereich KM Kundendienst Kfz Ausrüstung
© by Robert Bosch GmbH D 7 Stuttgart 1 Postfach 50 Printed in the Federal Republic of Germany
Imprimé en République Fédérale d'Allemagne par Robert Bosch GmbH

L4

Technical Bulletin

Alternators 0 120 4.., 28 V



Careful replacement of the steel sheet fan wheel when repairing or exchanging the alternator after operating for more than 100 000 km or 2000 running hours is still required.

Assembly examples for supporting plate 1 120 140 009

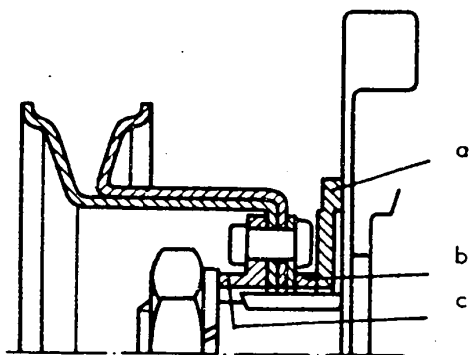

Fig. 1 Single-piece steel sheet pulley with deep hub

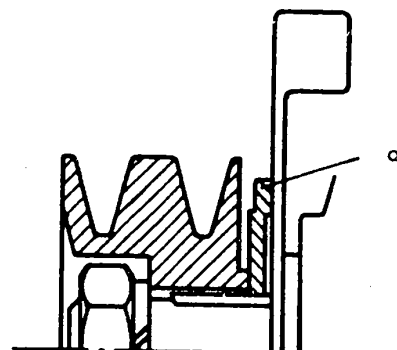

Fig. 2 Solid single-piece pulley

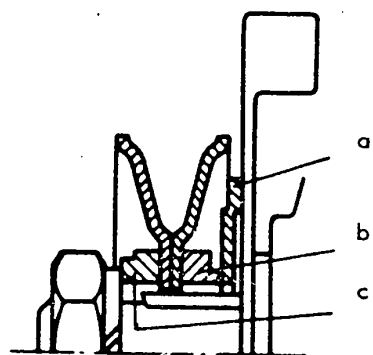

Fig. 3 Two-piece steel sheet pulley

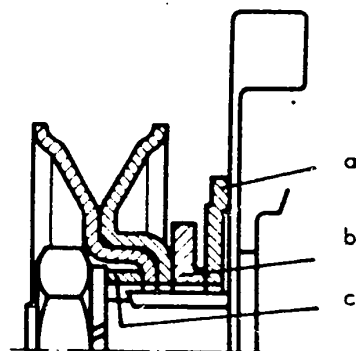

Fig. 4 Offset two-piece steel sheet pulley

Designation of individual components

- a Supporting plate 1 120 140 009
- b Rear slotted washer
- c Front slotted washer



After-sales Service

Technical Bulletin

Only for use within the Bosch organization. Not to be communicated to any third party.

EXTERNALLY MOUNTED TRANSISTOR REGULATOR 14 V ..

12

1 197 311 ..

VDT-I-120/105 En

2.1980

Supersedes Ed. 9.78

In addition to the already familiar EE externally mounted transistor regulators 0 192 052 .., the regulator 1 197 311 .. (EL 14 V ..) is finding increased application on a variety of different alternator models.

In case of complaints regarding the EL regulator 1 197 311 001/002 - for alternator collector ring with 32 mm diameter - the EL regulator 1 197 311 001 as well as the EE regulator 0 192 052 006 can be used as replacements.

When fitting an EE regulator, it must be taken into account that the housing is larger, that is, fitting space must be available.

The EL regulator 1 197 311 003 and .004 for alternator collector rings with a diameter of 28 mm can only be replaced by the model 1 197 311 003.

This regulator is fitted with a 68 Ω resistor between D+ and D-.

Further EL regulator models not listed here, and their replacements, are to be found in the EE microfiches of the alternators concerned.

It is not possible to fit a regulator with lengthened brush holder (for alternators with collector-ring diameter 28 mm) to alternators with collector-ring diameter 32 mm. Neither can the regulator with lengthened brush holder for 32 mm diameter be fitted to the 28 mm dia. model.

The production of alternators with a collector-ring diameter of 28 mm instead of 32 mm is increasing.

Warranty procedure

The normal warranty conditions apply to the regulator 1 197 311 .. (EL 14 V ..).

In the case of justified complaints, the precise part number of the alternator is to be entered in the column for the damaged product.

BOSCH

Geschäftsbereich KH Kundendienst Kfz-Ausrüstung
© by Robert Bosch GmbH D-7 Stuttgart 1 Postfach 50 Printed in the Federal Republic of Germany
Imprimé en République Fédérale d'Allemagne par Robert Bosch GmbH

L6

Technical Bulletin

Alternators 0 120 4.., 28 V

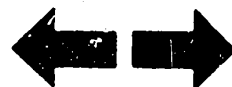

After-sales Service

Technical Bulletin

Only for use within the Bosch organization. Not to be communicated to any third party.

SOLUTION TO THE WIRING-HARNESS REPAIR PROBLEM

12

on alternators with attached-type regulators
and plug-in connection for B+ and B-

VDT-I-120/106 En
3.1979

In most vehicles the cable connections from the alternator/generator are welded to the wiring harness plug. This means that if the plug is damaged, a repair cannot be carried out.

In order to make repair possible, therefore, we have introduced a plug housing with 3 blade terminals into the program. Part number: 1 297 011 001. Remove the old plug-in connection, strip about 1 cm of insulation from the wire and crimp on the new blade terminals using the Eisemann crimping tool. Fit the blade terminals in the plug housing.

This parts set will be included in the service-parts lists for the generators/alternators in question.

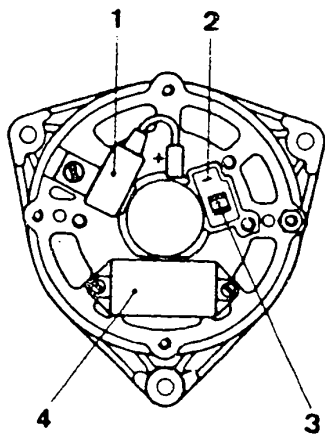

- 1 = Suppression capacitor
- 2 = Blade terminal 3.3 x 0.6 (D+)
- 3 = Blade terminals 9.5 x 1.2 (B+)
- 4 = Transistor regulator

Fig. 1 Plug-in connection

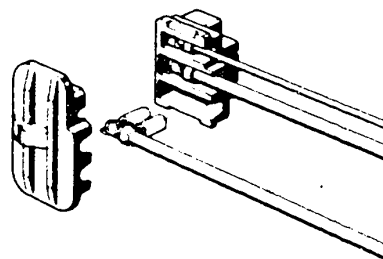

Fig. 2 Plug housing with blade terminals

BOSCH

Geschäftsbereich KH Kundendienst Kfz-Ausrüstung
© by Robert Bosch GmbH, D-7 Stuttgart 1, Postfach 50 Printed in the Federal Republic of Germany
Imprimé en République Fédérale d'Allemagne par Robert Bosch GmbH

L7

Technical Bulletin

Alternators 0 120 4.., 28 V

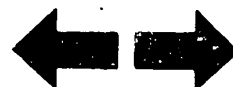

After-sales Service

Technical Bulletin

Only for use within the Bosch organization. Not to be communicated to any third party.

ALTERNATORS 0 120 ..

12

VDT-I-120/107 En

9.1979

Alternator operation without battery

General

Unless special measures are taken, alternators are not to be operated without the battery connected because otherwise this can lead to the destruction of semiconductor components in the regulator, alternator or vehicle electrical system.

In the case of special-purpose vehicles, auxiliary or stationary equipment, or vehicle export, it can be necessary for the alternator to operate without battery - with or without power output.

With systems where the regulator is mounted separately from the alternator, the alternator is placed out of operation before starting by open-circuiting the line between it and the regulator. Power output is now impossible.

This method cannot be used with systems having an attached-type regulator. In such cases, the following methods are used. Details can be taken from the product specifications.

1. Systems with increased voltage-proof characteristics

A variety of vehicle manufacturers order such systems because during shipping it can occur that operation takes place without battery. In such exigencies, power output is possible depending upon alternator speed. These measures protect the alternator and regulator but not the loads.

2. Zener diode 1 127 328 .. for 14 V alternators and max. 35 A

This Zener diode is connected to Terminal B+ of the alternator. If the voltage rises above the response voltage of the Zener diode this conducts and the voltage peak is conducted away through the diode heat sink to the alternator housing. In this way semicon-

BOSCH

Geschäftsbereich K.M. Kundendienst Kfz Ausrüstung
© by Robert Bosch GmbH D-7 Stuttgart 1 Postfach 50 Printed in the Federal Republic of Germany
Imprimé en République Fédérale d'Allemagne par Robert Bosch GmbH

L8

Technical Bulletin

Alternators 0 120 4.., 28 V



ductors in the alternator and regulator are protected against voltage peaks and if necessary the system can deliver power. If required, this Zener diode can be fitted as series equipment on new alternators or can be retro-fitted. Connection in parallel or series of these Zener diodes for the purpose of increasing the power is not possible.

Notes on testing are contained in Instructions VDT-W-120/300.

Burnt-out connections between Zener diode and alternator B+ are the result of false polarity during battery change, use of auxiliary starting aids or operation with 24 V etc. Warranty claims are therefore to be rejected.

3. Systems with over-voltage protection devices fitted

For years, such devices (OSG) have been available either integrated in the regulator e.g. 0 192 083 .. or separate 0 192 900 .. for use in 28 V systems.

When voltages occur in excess of the OSG response voltage, the Terminals D+ and D- are connected together by the OSG. The alternator is short-circuited and cannot self-excite. This means that resultant damage in the vehicle electrical system due to excessive alternator voltage is avoided.

As long as the OSG does not conduct, without battery connected, the alternator can deliver power.

4. Short-circuit capsule 1 120 505 000 for K1, N1 and T1 alternators

In order that the alternator does not self-excite during operation without battery, Terminals D+ and D- are connected together. At customer request, certain alternator models are equipped at the works with a short-circuit capsule connected to Terminal D+ for this reason. This enables engines and vehicles to be tested on dynamometers etc. without the battery being connected. Power cannot be taken from the alternator.

After the battery is connected the capsule is removed so that the system is ready for operation. If, subsequently, operation without battery is required, D+ and D- must be connected together again.

Details regarding the Part Numbers of the products dealt with in this Bulletin can be requested from your local Bosch representative.



After-sales Service

Technical Bulletin

Only for use within the Bosch organization. Not to be communicated to any third party.

ADDITIONAL IDENTIFICATION OF
ALTERNATORS 0 120 ..

VDT-I-120/116 En
4.1981

Since date of manufacture FD 143 (March 1981) the alternators fitted with stick-on nameplates have received an additional identification. This takes the form of stamping the last 4 figures of the appropriate part number on a suitable place on the front of the collector-ring end shield. The figures are 4 mm high. The exterior characteristics of the alternators make it possible to find out the remaining 6 figures of the part number.

Since the introduction of this additional identification, the part number of an alternator can be ascertained even if the nameplate is missing or has become illegible. This makes it easier to find technical data in such cases, as well as to quote the full part number in correspondence or in guarantee claims.

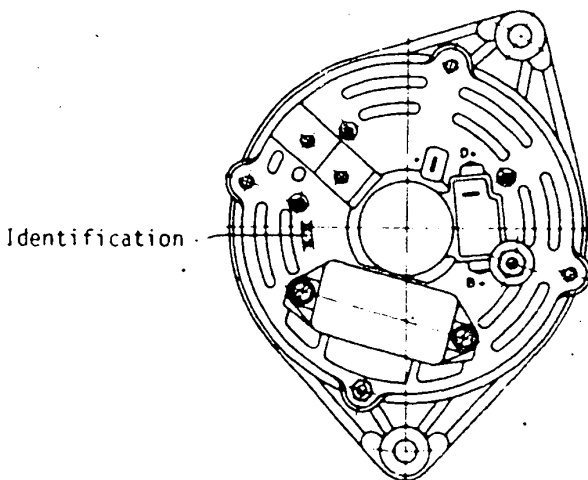

BOSCH

Geschäftsbereich KH, Kundendienst, Kfz-Ausrüstung
© by Robert Bosch GmbH, D-7 Stuttgart 1 Postfach 50. Printed in the Federal Republic of Germany.
Imprimé en République Fédérale d'Allemagne par Robert Bosch GmbH.

L10

Technical Bulletin

Alternators 0 120 4..., 28 V



Contents

Section

Coordinates

Layout of the Microfiche	A 1
1. Electrical test data	A 2
2. Mechanical test data	A 4
3. Alternator circuit diagram	A 7
4. General instructions	A 8
5. Test equipment, tools and adhesives	A 10
6. Exploded view	A 13
7. Dismantling the alternator and testing the parts	B 1
7.1 Testing the voltage regulator for external damage and replacing the carbon brushes	B 3
7.2 Testing the suppression capacitor	B 4
7.3 Testing the rectifier	B 7
7.4 Testing the stator (resistance)	B 8
7.5 Testing the stator (short-circuit to ground)	B 10
7.6 Testing the rotor resistance	B 14
7.7 Testing the rotor for short-circuit to ground	B 15
7.8 True-running test	B 16



Contents (continued)

<u>Section</u>	<u>Coordinates</u>
8. Cleaning the parts	B 19
9. Assembling the alternator	C 1
9.1 Installing the rectifier	C 5
9.2 Installing the starter and the rotor	C 8
9.3 Installing the regulator and the suppression capacitor	C 10
10. Testing the alternator with regulator on the test bench	D 1
10.1 Test equipment and devices	D 1
10.2 Testing with the oscilloscope	D 6
Technical Bulletins	L 1

© 1982 Robert Bosch GmbH
Automotive Equipment - After-Sales Service,
Department for Technical Publications KH/VDT,
Postfach 50, D-7000 Stuttgart 1

Published by: After-Sales Service, Department for
Training and Technology (KH)VSK). Press date: 10.1982

Please direct questions and comments concerning the
contents to our authorized representative in your
country.

This publication is only for the use of the Bosch
After-Sales Service Organization, and may not be passed
on to third parties without our consent.

Microfilmed in the Federal Republic of Germany.
Microphotographié en République Fédérale d'Allemagne.

L24

Index

Alternators 0 120 4.., 28 v

